

SETUP INSTRUCTIONS

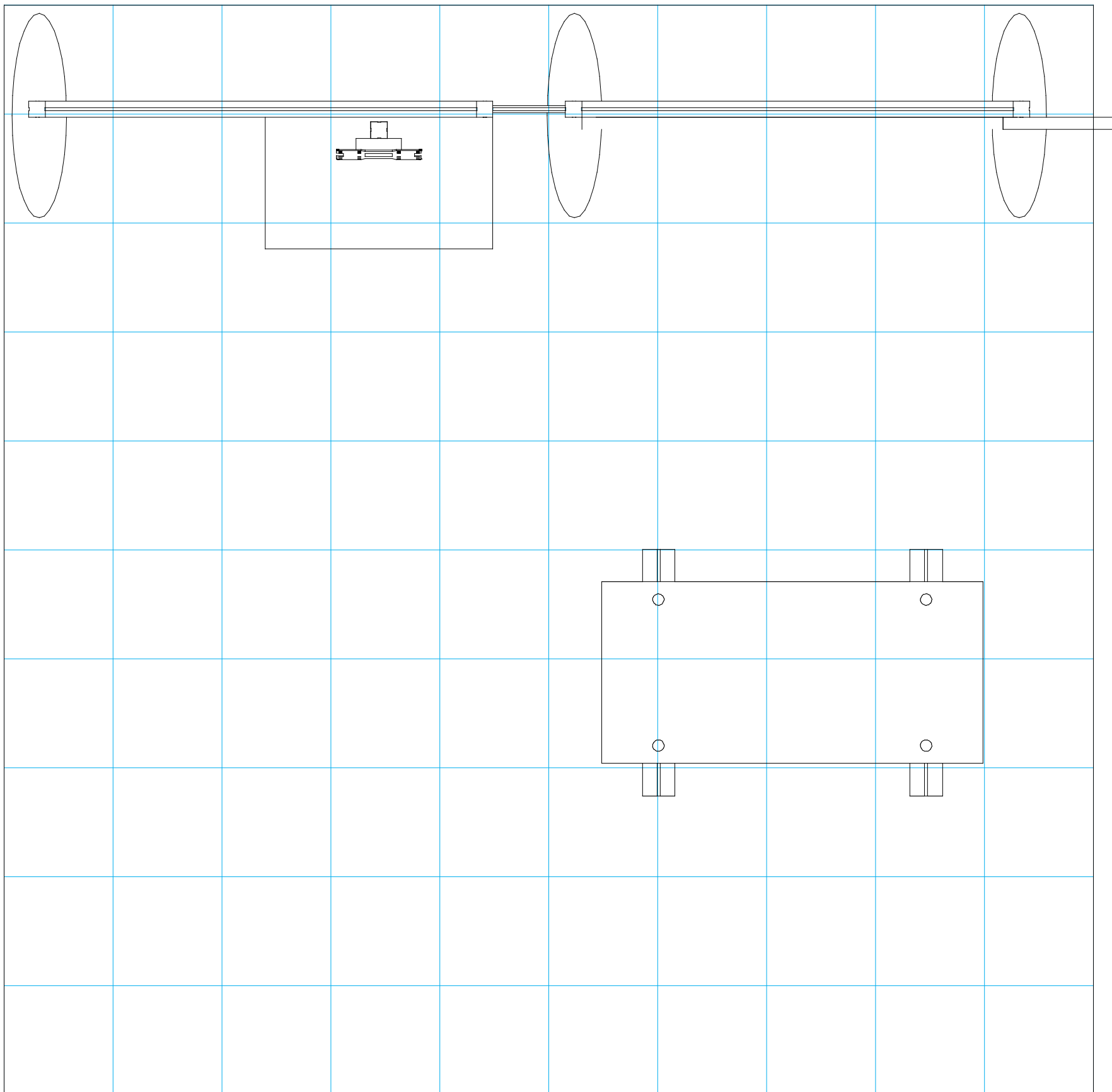

= 1 sq foot

General Setup Instructions

- Read entire setup instruction manual prior to unpacking parts and pieces.
- The setup instructions are created specifically for this configuration.
- Setup instructions are laid out sequentially in steps, including exploded views with detailed explanation for assembly.

Cleaning & Packing

- For Cleaning Metal, Plex, & Laminate Parts: Use a **MILD NON-ABRASIVE** cleanser and soft cloth/paper towel to clean all surfaces.
- Keep exhibit components away from heat and prolonged sun exposure. **Heat and UV exposure will warp and fade components.**
- Retain all provided Packing Materials. All provided packing materials are for ease of repacking & component protection.

Disassembly

- For loss prevention, tighten all set screws and locks during disassembly.

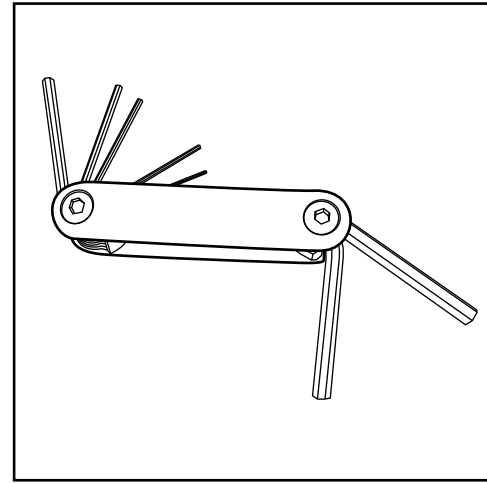

Hex Tool - Essential for Assembly

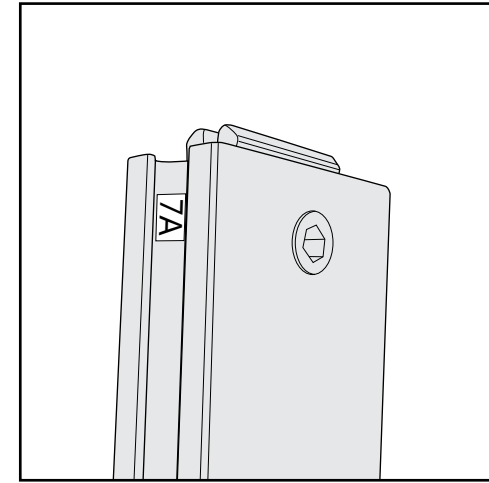

Part Identification - Numbering

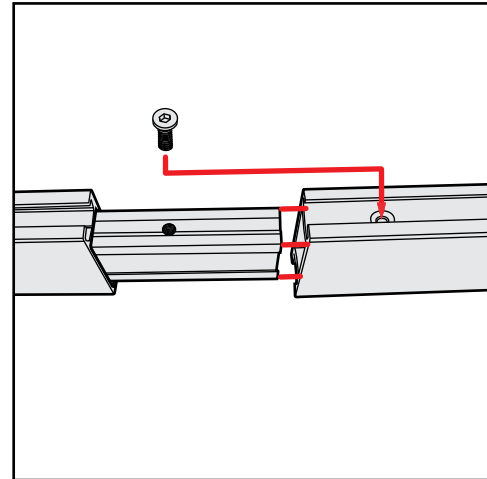

Spline Connection

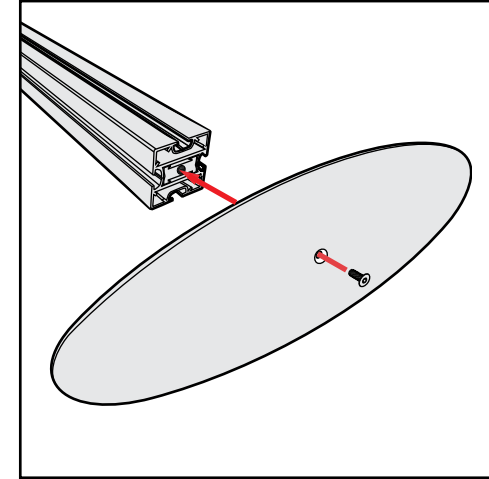

Base Plate & Extrusion Connection

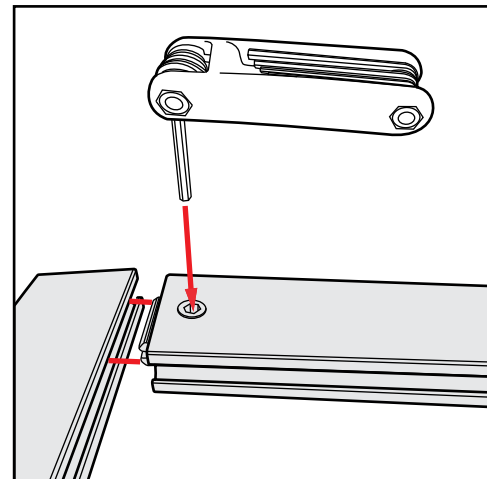

Extrusion & Lock Connection

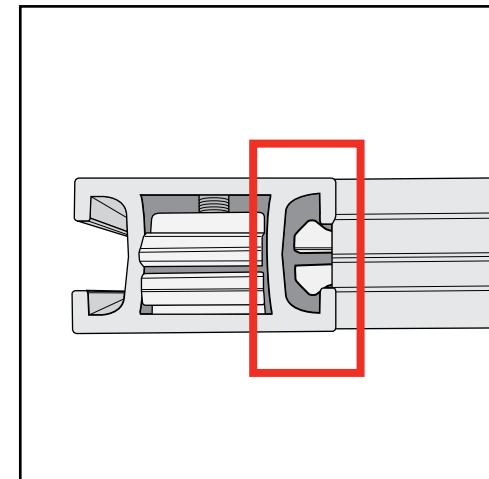

Engaged Lock



WARNING



DO NOT USE POWER TOOLS



LADDERS OR LIFTS
MAY BE REQUIRED



ALL CONNECTIONS MUST
BE TIGHTLY SECURED

The Perfect Fit

SEG Graphic Installation *in 3 Steps*

STEP 1: Attach Corners

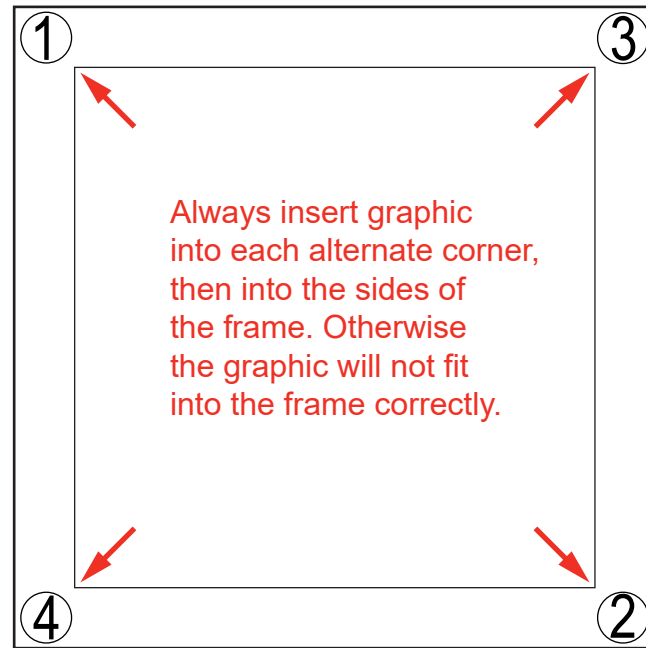

STEP 2: Attach Middle

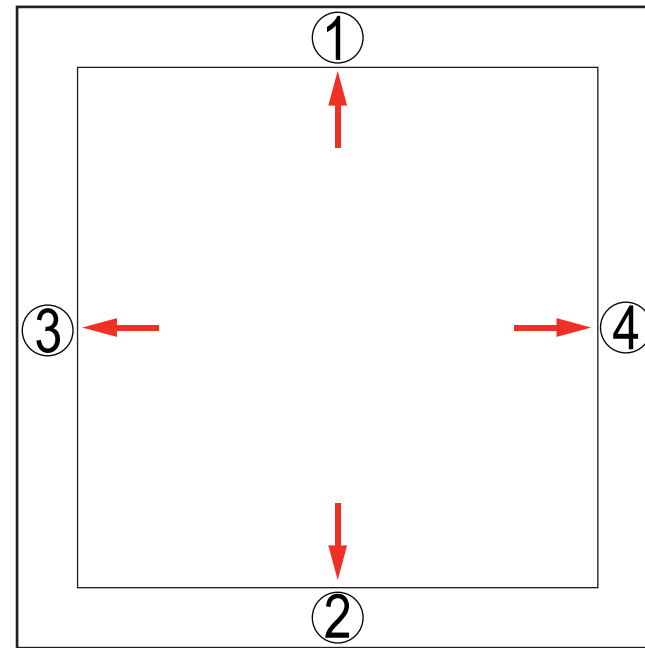

STEP 3: Attach Sides

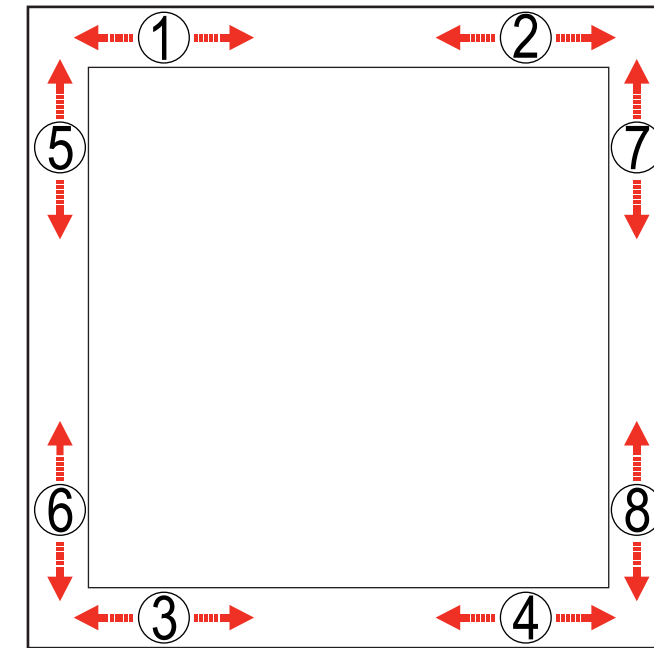

Insert narrow side of silicone welt into the channel at corner 1, with fabric to the outside.

Repeat for opposite corner 2, then corner 3, then corner 4.

Once corners are attached, press the middle of edge 1 into the channel. Then press middle of edge 2 into the channel on opposite side.

Repeat with edge 3 & 4.

Once the middle of sides are attached, fully press the silicone welt into the channel, between center and corner at location 1. Repeat the process between center and corner at location 2.

Do the same for welt on opposite side, at locations 3 & 4. Then repeat for locations 5 & 6 and 7 & 8.

Once the welt is fully inserted on all sides, smooth out edges as needed for a perfect fit.



To remove the graphic from the frame, locate the fabric **pull tab**. Gently pull on the tab to remove the graphic.

Install video:



CRATE PACKING

Item	Qty.	Description
1	3	
2/2A	1/1	95" Vertical Extrusion
3/3A	1/1	95" Vertical Extrusion
4/4A	1/1	47.5" Horizontal Extrusion
5/5A	1/1	47.5" Horizontal Extrusion
6/6A	1/1	8" Horizontal Extrusion

Steps:

- 1) Connect Baseplates [1] to ends of Verticals [2, 3, 4A] as shown.
- 2) Connect Horizontals [4, 4A] to Vertical [2] and insert Infill between [4, 4A].
- 3) Connect Vertical [2A] to [4, 4A].
- 4) Connect Horizontals [6, 6A] to Vertical [2A], then insert Infill between [6, 6A].
- 5) Connect Vertical [3] to [6, 6A].
- 6) Connect Horizontals [5, 5A] to [3], then insert Infill between [5, 5A].
- 7) Connect Vertical [3A] to [5, 5A].

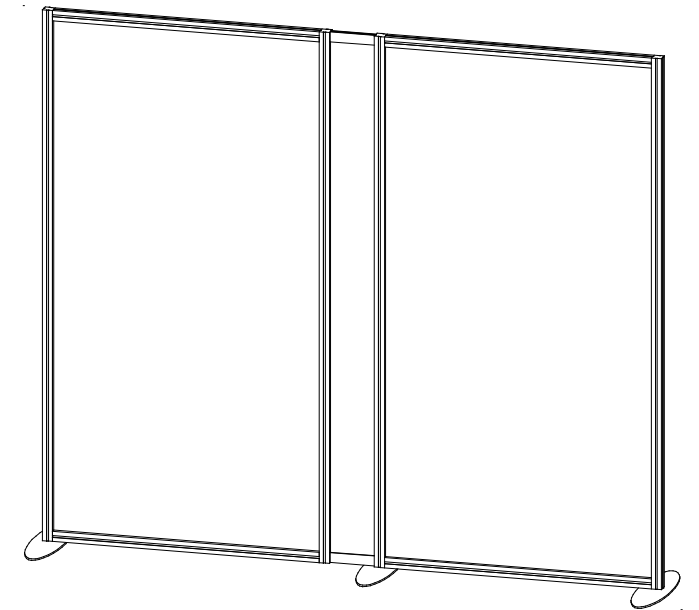
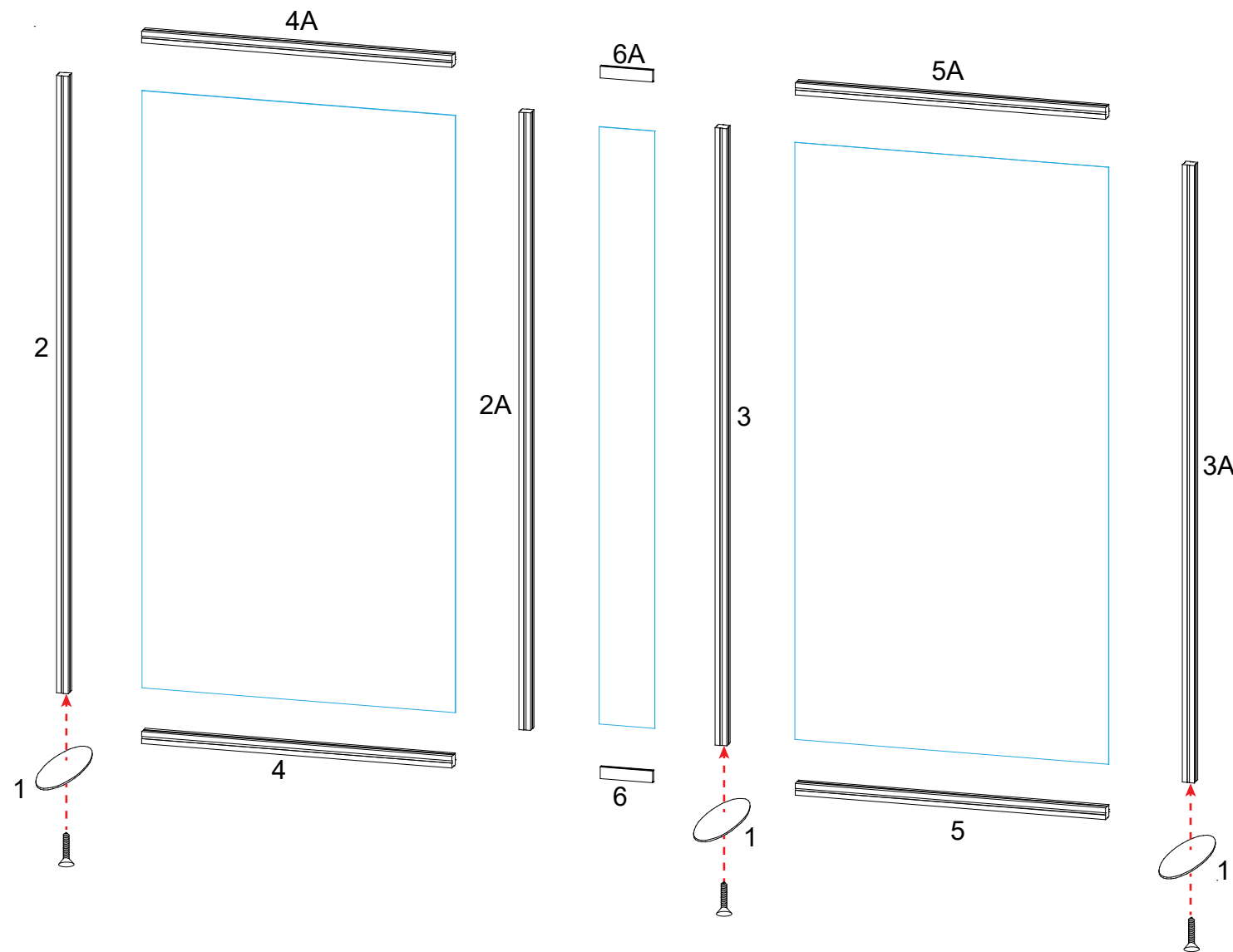

When assembled

Item	Qty.	Description
6	1	70" Vertical Extrusion

- Steps:
- 1) Install Shelf supports using **Velcro** on the inside where indicated.
 - 2) Slide Shelf inside counter and set in place on the shelf supports.
 - 3) Place Countertop onto assembled base and lock into place.
See **Counter Top Attachment** detail.
 - 4) Lower vertical [6] down through the hole in the counter and set in place.
 - 5) Attach Monitor Mount to vertical [6] where indicated.
See **Monitor Mount Attachment** detail.

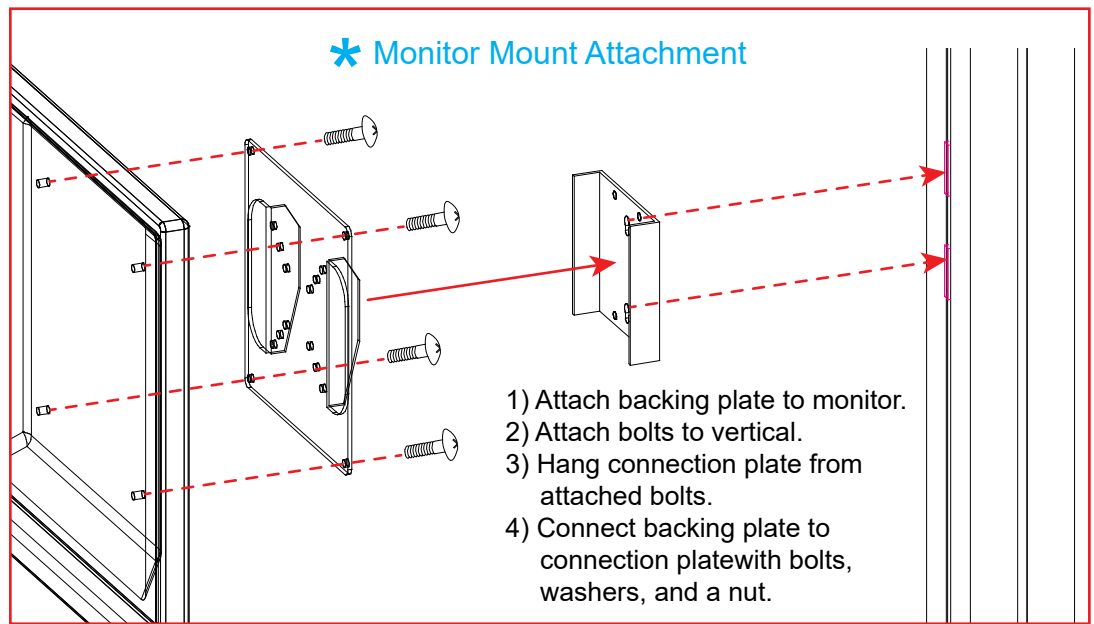
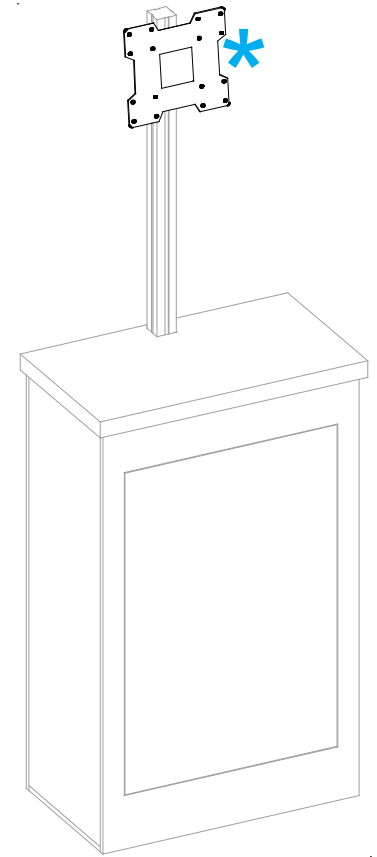
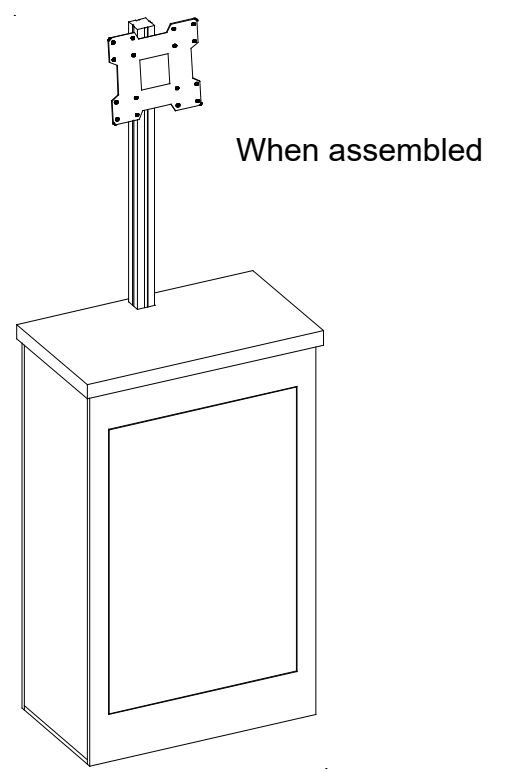
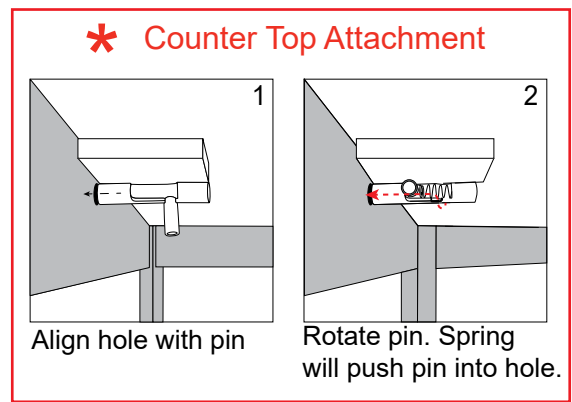
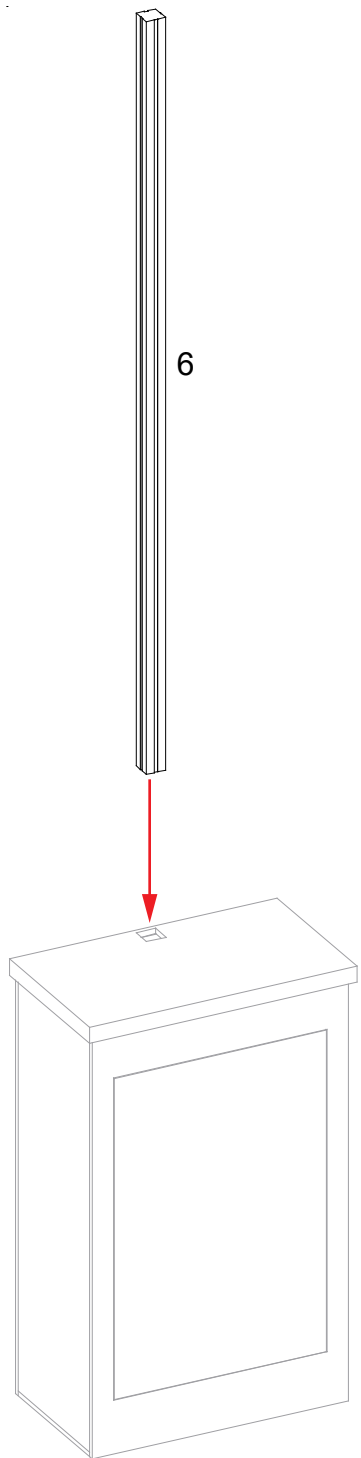
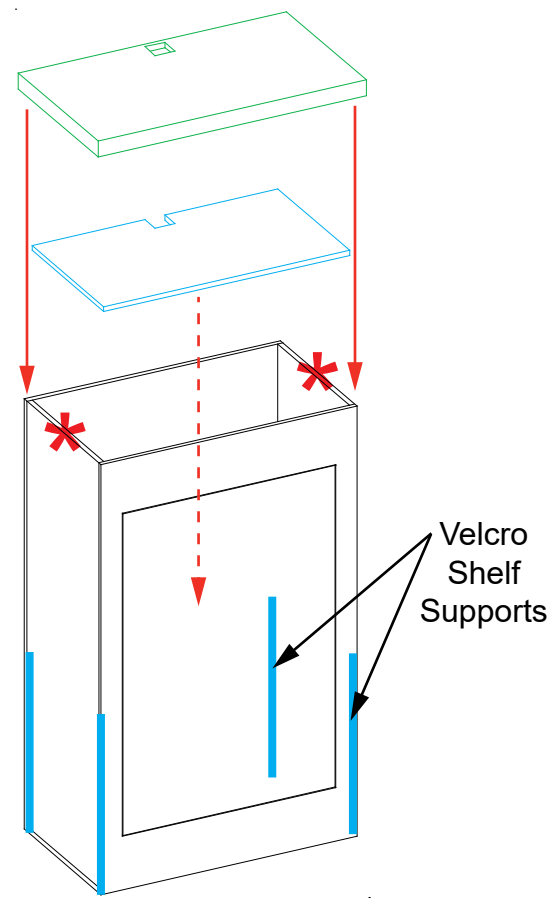

Item	Qty.	Description
7/7A	1/1	48" Horizontal Extrusion
8/8A	1/1	48" Vertical Extrusion

Steps:

- 1) Connect Horizontals [7, 7A] to Verticals [8, 8A] together at corners as shown.
- 2) Connect assembled frame to backwall as shown using bolts. See **TSP Frame Attachment** detail.

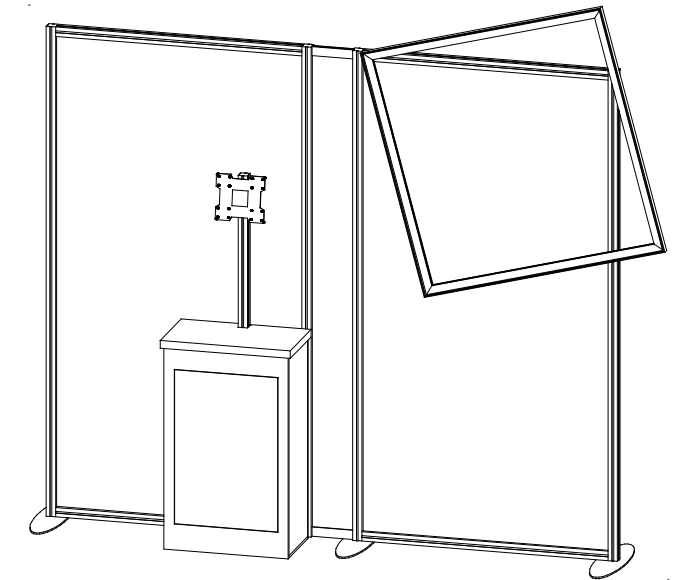
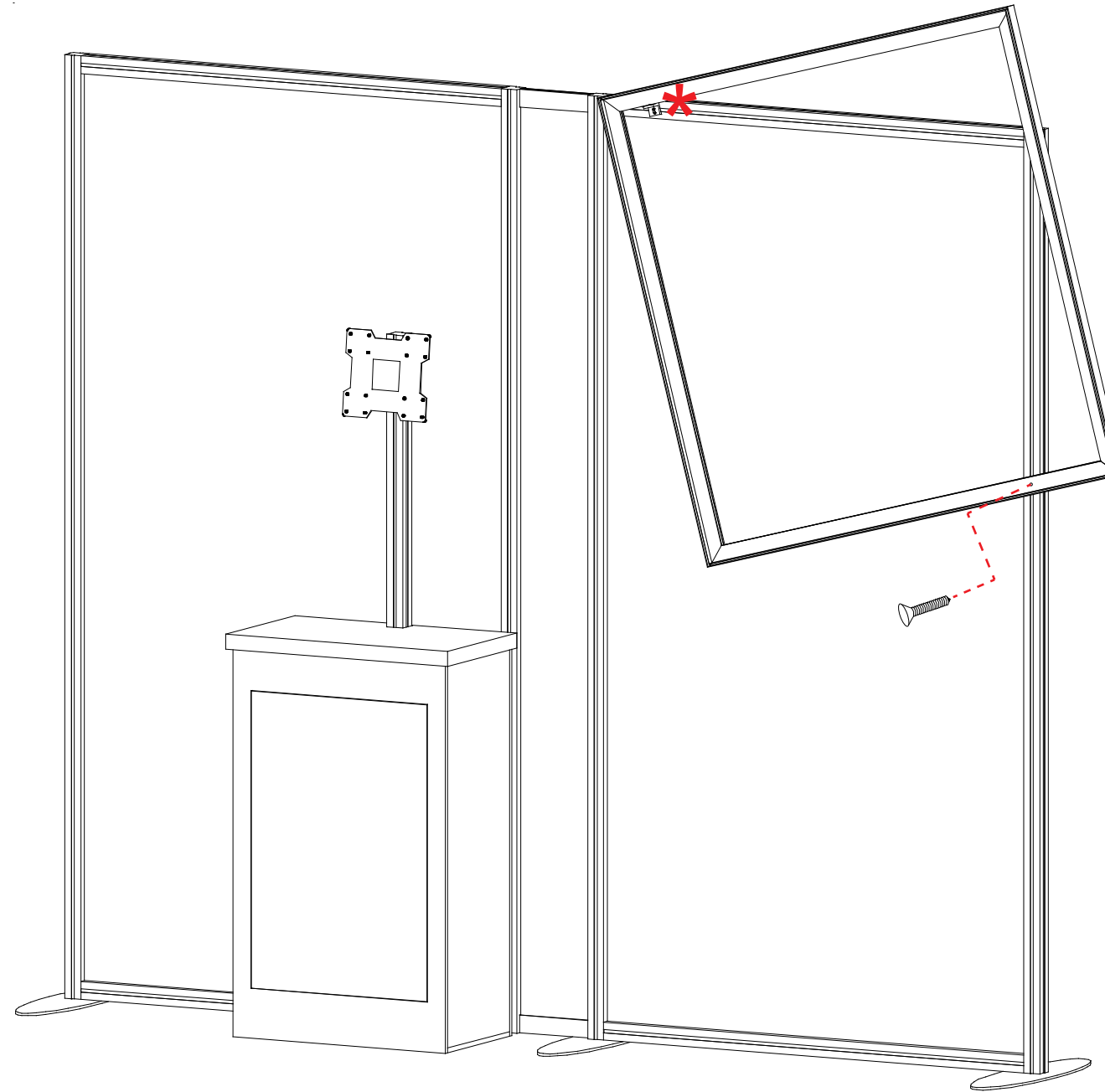
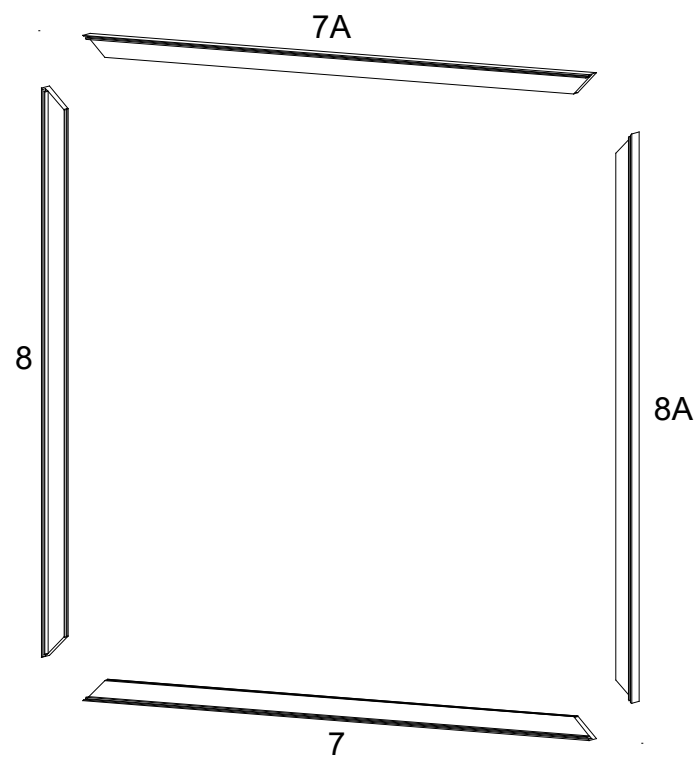

When assembled

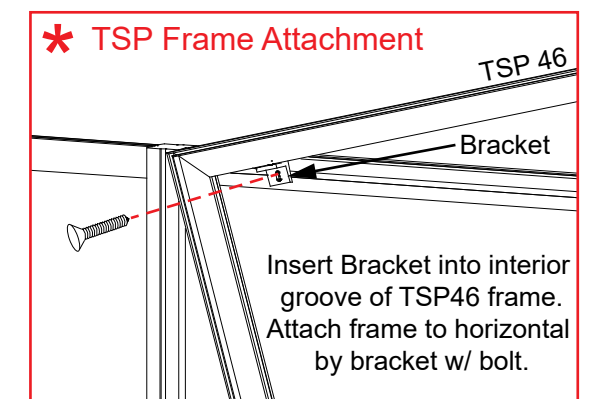

Item	Qty.	Description
9/9A	1/1	27.166" Horizontal Extrusion
10/10A	1/1	27.166" Horizontal Extrusion
11/11A	1/1	31.334" Vertical Extrusion
12/12A	1/1	31.334" Vertical Extrusion

Steps:

- 1) Attach verticals [11, 11A & 12, 12A], between horizontals [9, 9A & 10, 10A] as shown.
- 2) Attach Countertop to assembled base with Standoff Caps as shown.

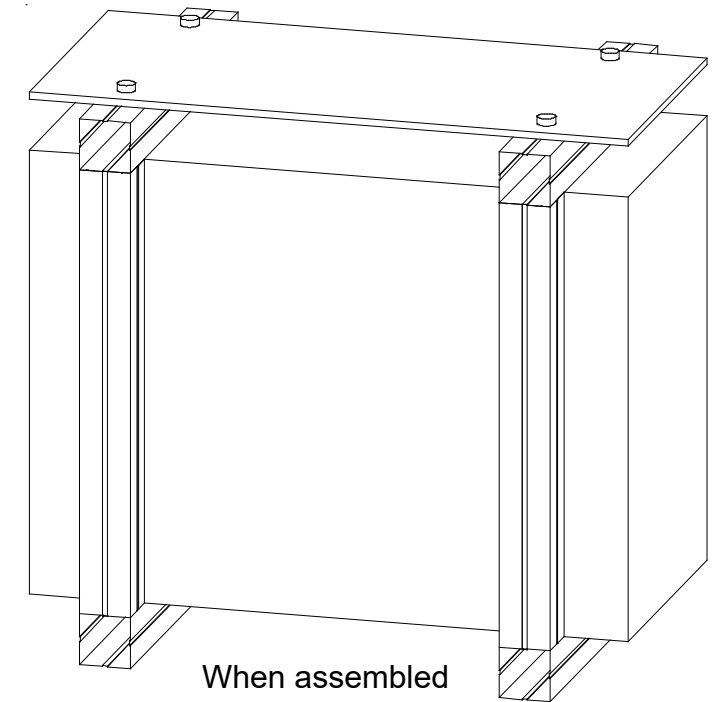
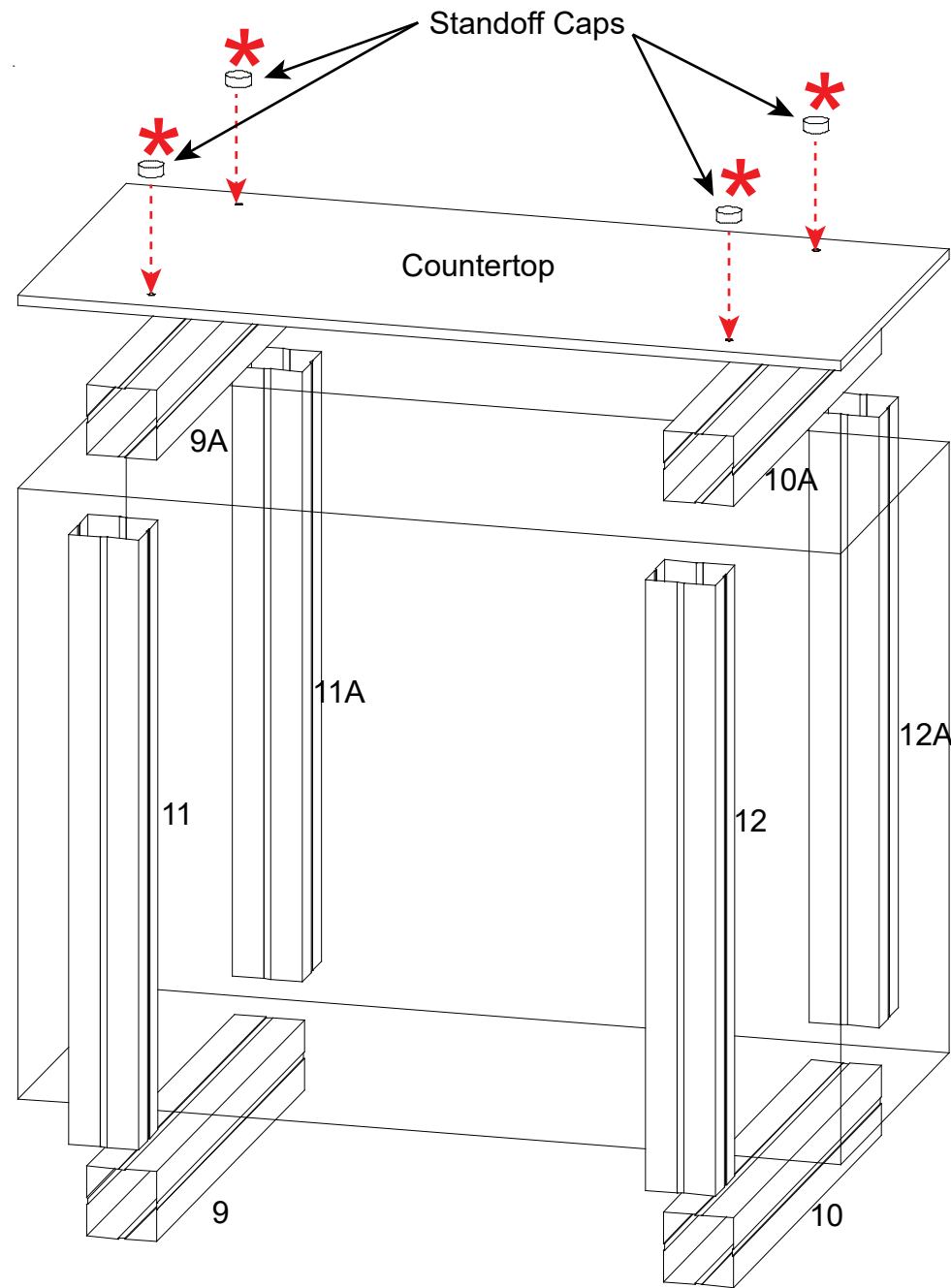

*** Countertop Attachment**

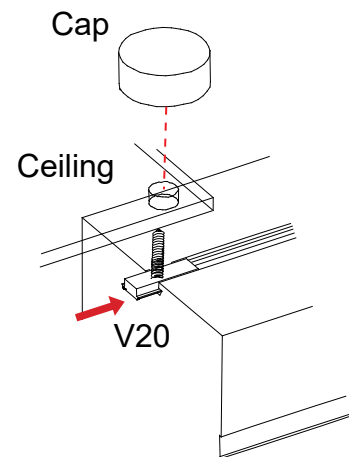

Slide connector with stud into groove of extrusion and twist to secure in place. Attach ceiling with cap as shown.