

Top View

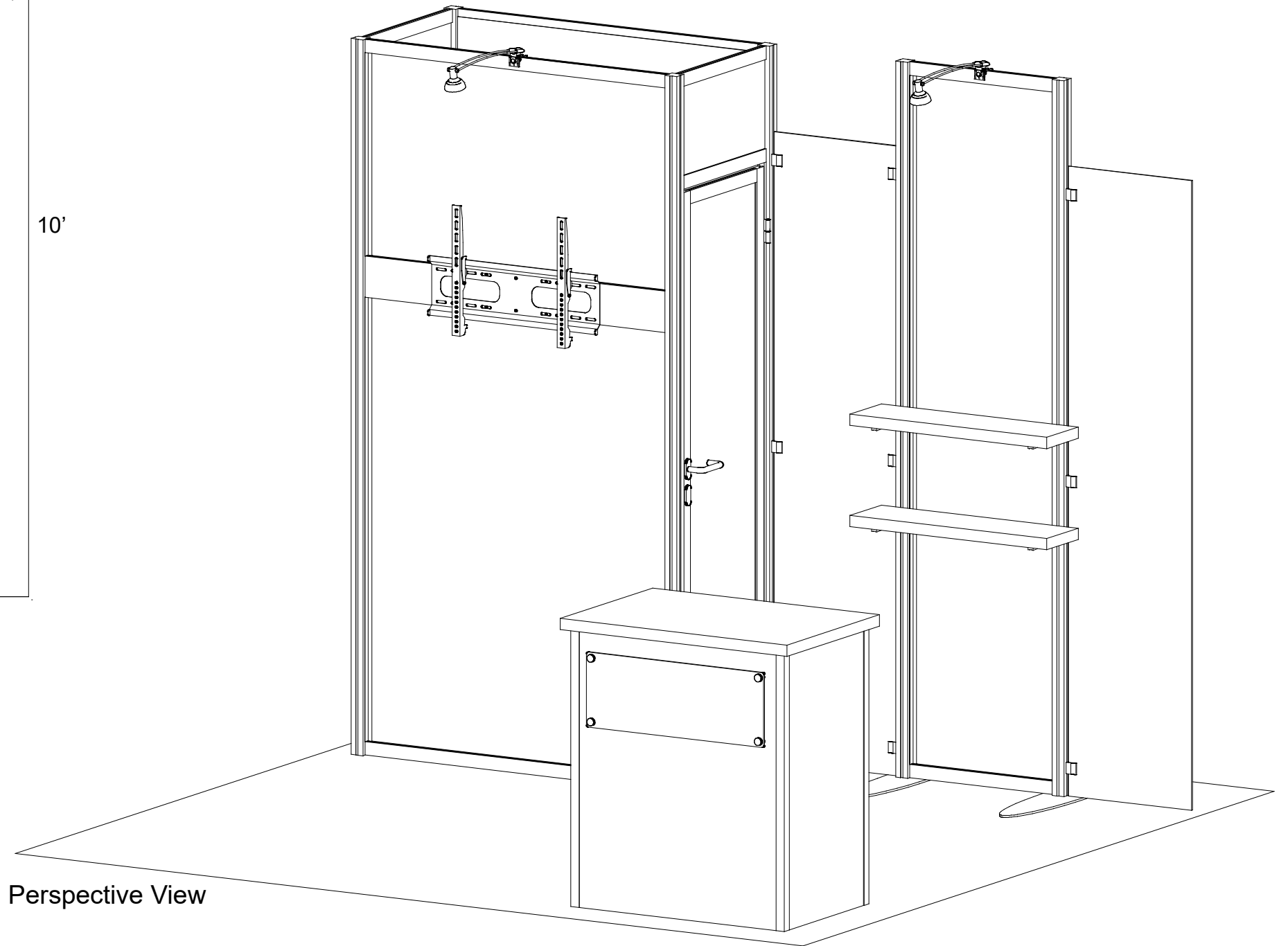

Perspective View

SETUP INSTRUCTIONS

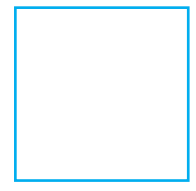
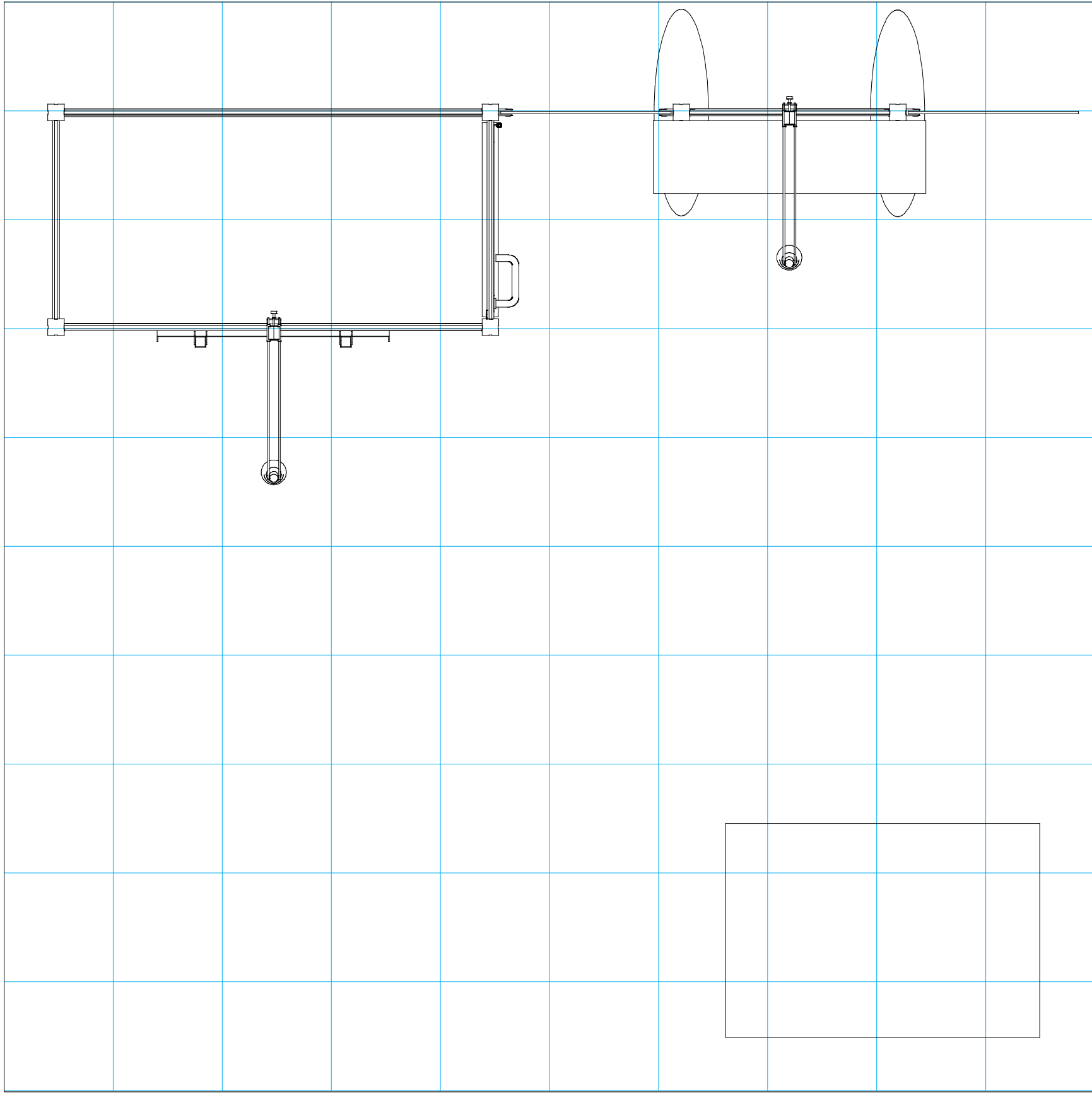

= 1 sq foot

General Setup Instructions

- Read entire setup instruction manual prior to unpacking parts and pieces.
- The setup instructions are created specifically for this configuration.
- Setup instructions are laid out sequentially in steps, including exploded views with detailed explanation for assembly.

Cleaning & Packing

- For Cleaning Metal, Plex, & Laminate Parts: Use a **MILD NON-ABRASIVE** cleanser and soft cloth/paper towel to clean all surfaces.
- Keep exhibit components away from heat and prolonged sun exposure.
Heat and UV exposure will warp and fade components.
- Retain all provided Packing Materials. All provided packing materials are for ease of repacking & component protection.

Disassembly

- For loss prevention, tighten all set screws and locks during disassembly.

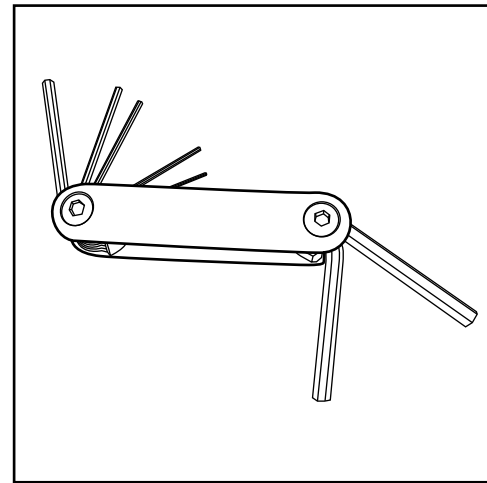

Hex Tool - Essential for Assembly

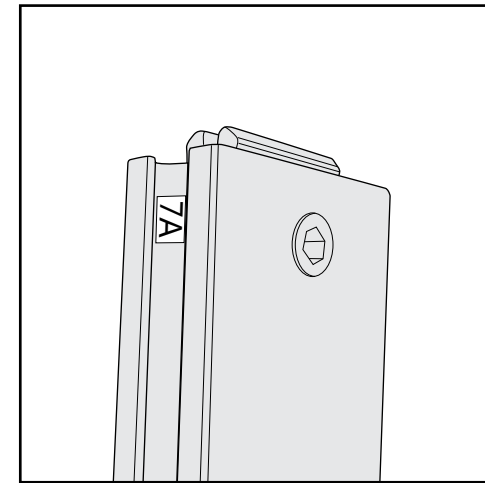

Part Identification - Numbering

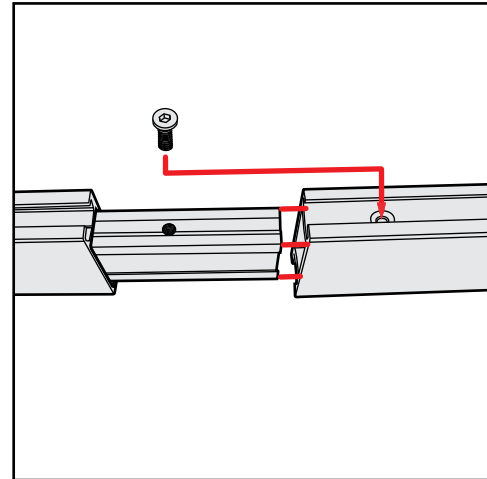

Spline Connection

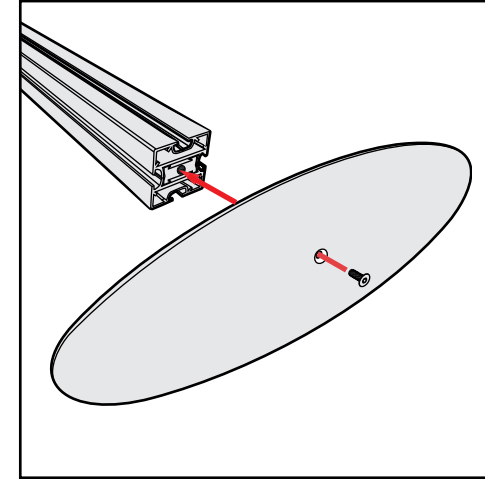

Base Plate & Extrusion Connection

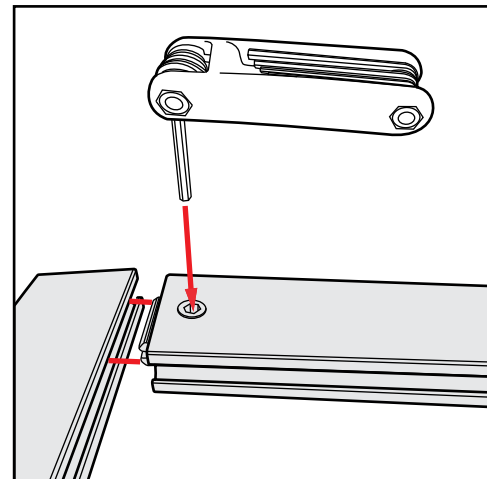

Extrusion & Lock Connection

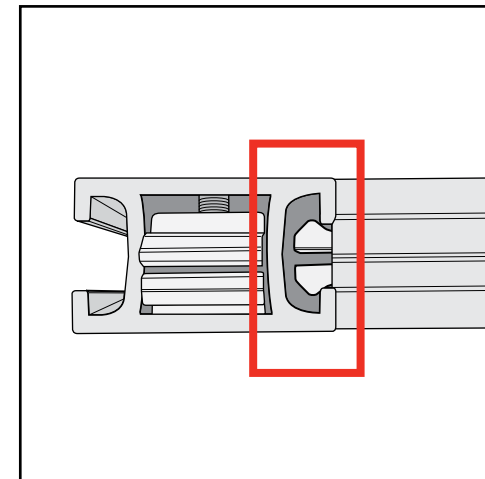

Engaged Lock



WARNING



DO NOT USE POWER TOOLS

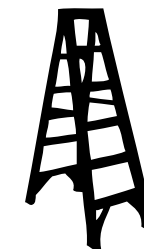

LADDERS OR LIFTS
MAY BE REQUIRED



ALL CONNECTIONS MUST
BE TIGHTLY SECURED

CRATE PACKING

Item	Qty.	Description
1	1	95.5" S44 Vertical Extrusion w/ PR37
2	1	95.5" S44 Vertical Extrusion w/ PR37 w/ Door Hinge
3	1	95.5" S44 Vertical Extrusion w/ PR37 w/ Door Stop
4	1	95.5" S44 Vertical Extrusion w/ PR37
5,5A	2,2	45" Z45 Horizontal Extrusion
6	4	21.833" Z45 Horizontal Extrusion
7	1	45" Z140 Horizontal Extrusion

Steps:

- 1) Attach horizontals [5] and [5A] between verticals [1] and [2], making sure Velcro is facing inward.
- 2) Attach horizontals [6] between verticals [2] [3] and [1] [4], with infills between, as shown.
- 3) Attach horizontal [7] between [3] and [4].
- 4) Connect Door Threshold between verticals [2] and [3].
See [Door Threshold Attachment](#) detail.
- 5) Connect Door between verticals [2] and [3]. See [Door Connection](#) detail.

Keep PR37 attached to extrusions [1] [2] [3] and [4], when packing.

Keep closet sides assembled, when packing.

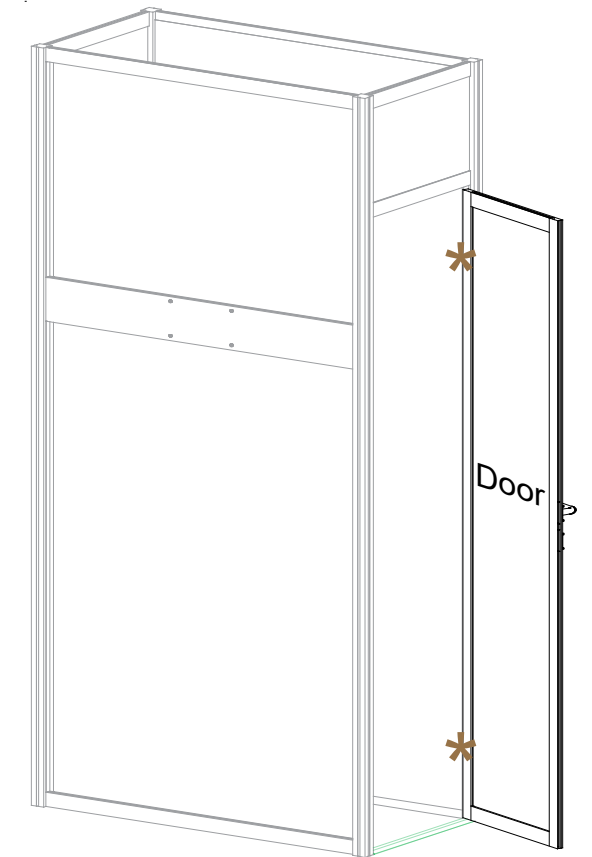
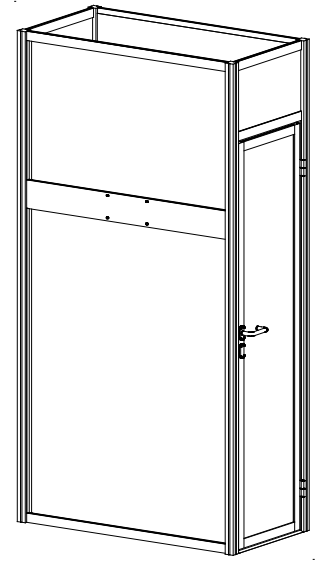
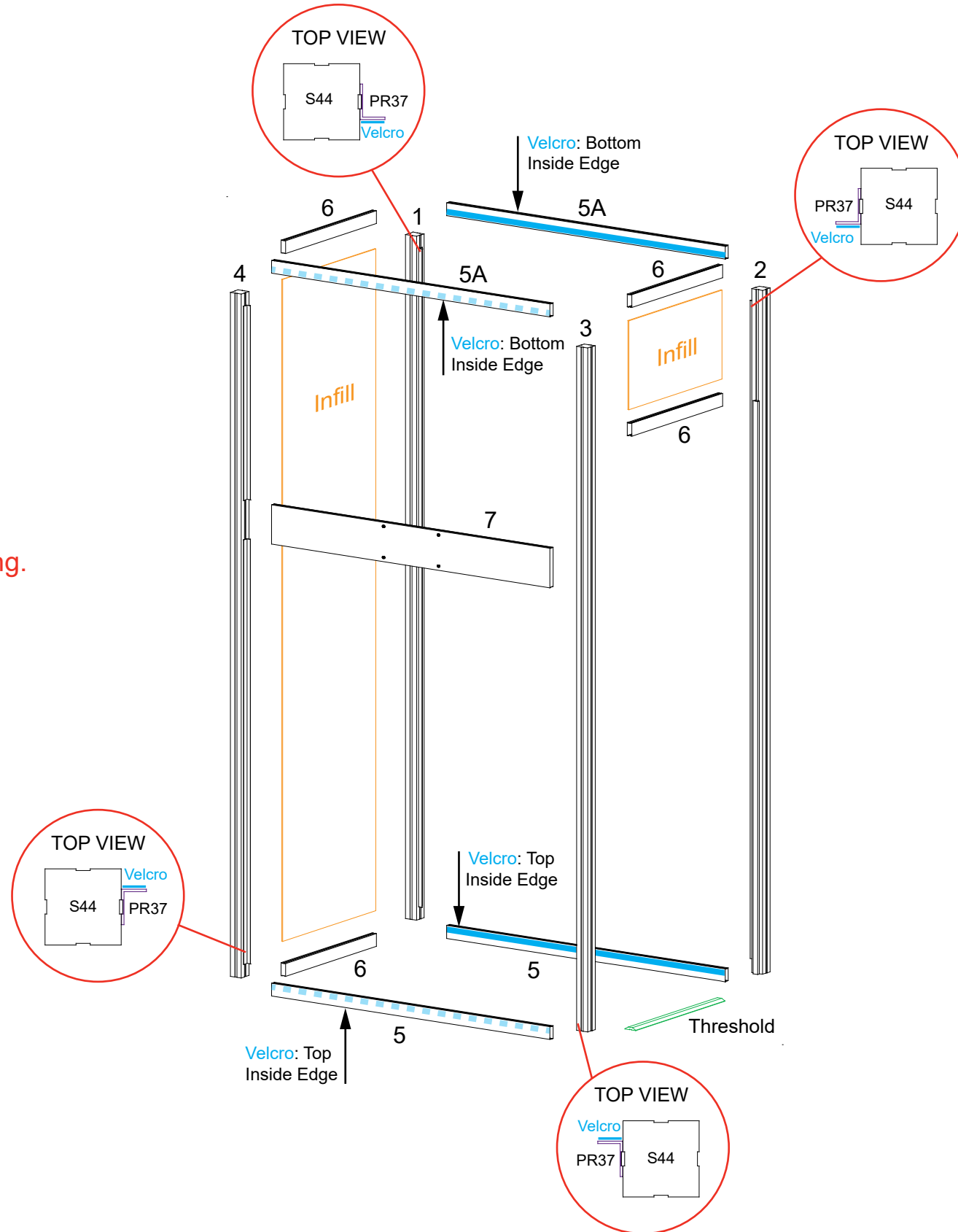
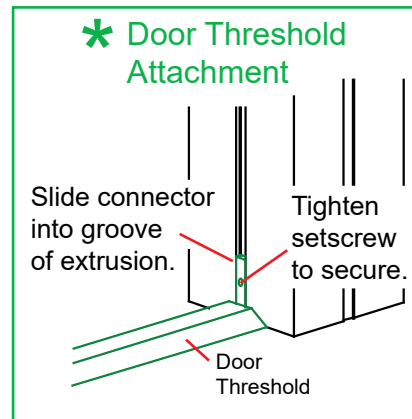

Item	Qty.	Description
8	1	Base Plate
9	1	95.5" S44 Vertical Extrusion w/ PR37
10	2	95.5" S44 Vertical Extrusion w/ PR37
11	2	22" Z45 Horizontal Extrusion
--	2	18.75"w x 84"h Panel

- Steps:**
- 1) Attach base plates [8] to verticals [9] and [10], using bolts.
 - 2) Attach horizontals [11] between verticals [9] and [10], making sure Velcro is facing toward back.
 - 3) Attach clamps to vertical [2]. See **Clamp Attachment** detail.
 - 4) Attach panels to clamps, as shown.
 - 5) Connect fabric graphics to Velcro inside closet and back of backwall.

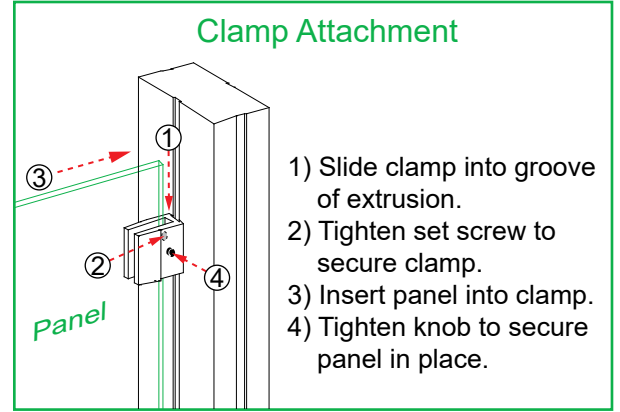

Keep PR37 and clamps attached to extrusions [9] and [10], when packing.

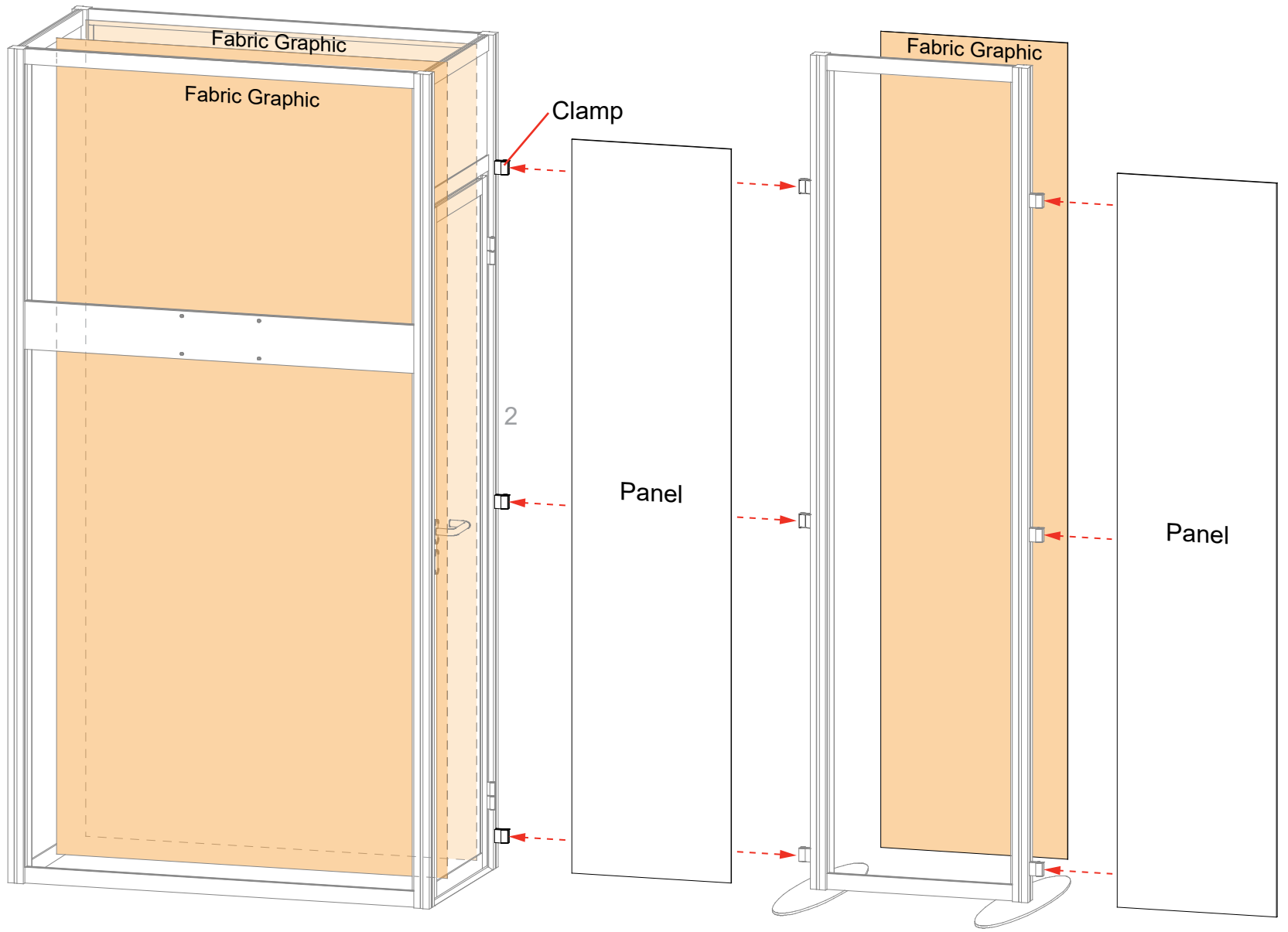
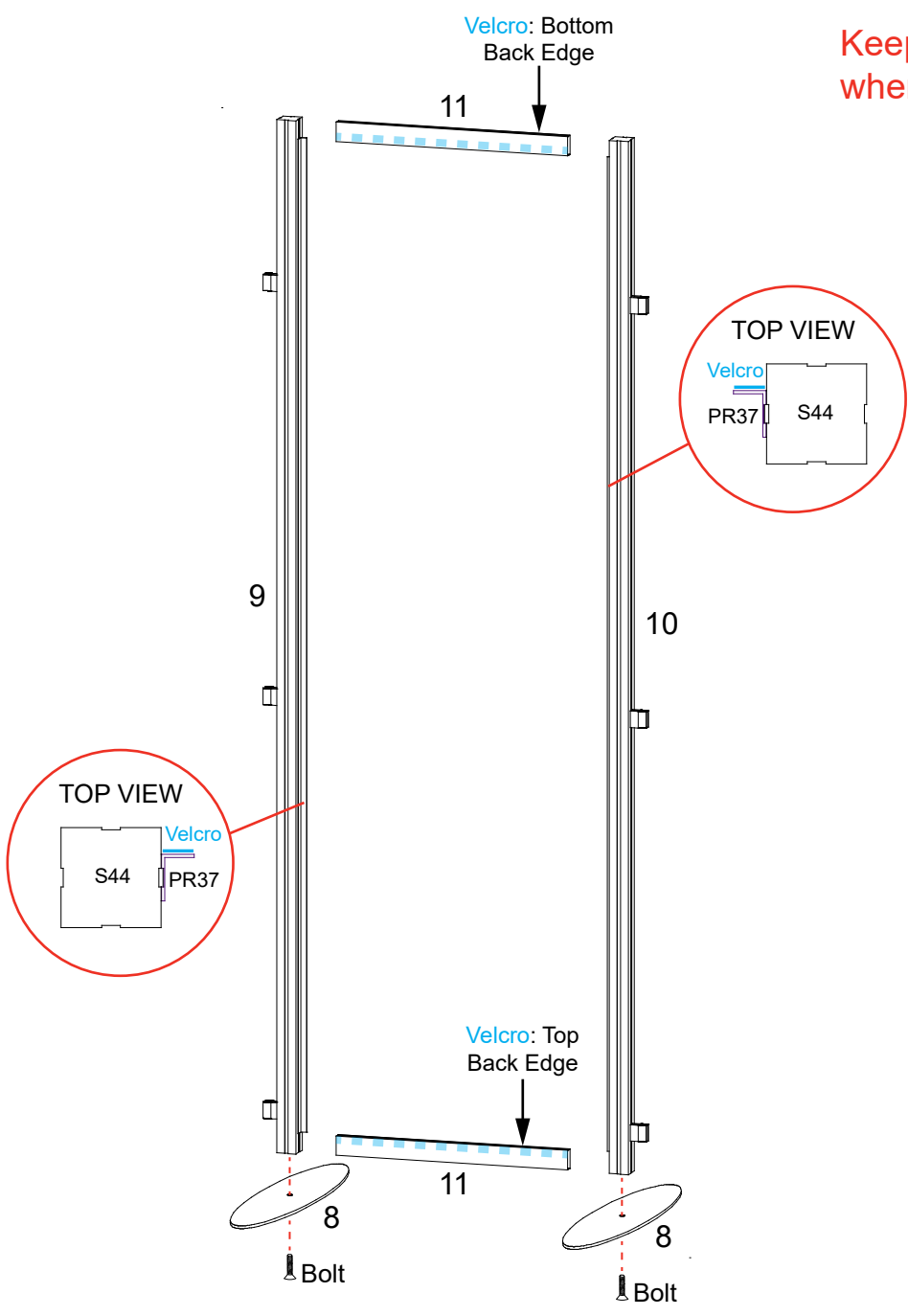

Steps:

- 1) Attach lights to horizontals [5A] and [11]. See [Light Attachment](#) detail.
- 2) Attach monitor mount to horizontal [7]. See [Monitor Mount Attachment](#) detail.
- 3) Attach shelves to verticals [9] and [10]. See [Shelf Attachment](#) detail.

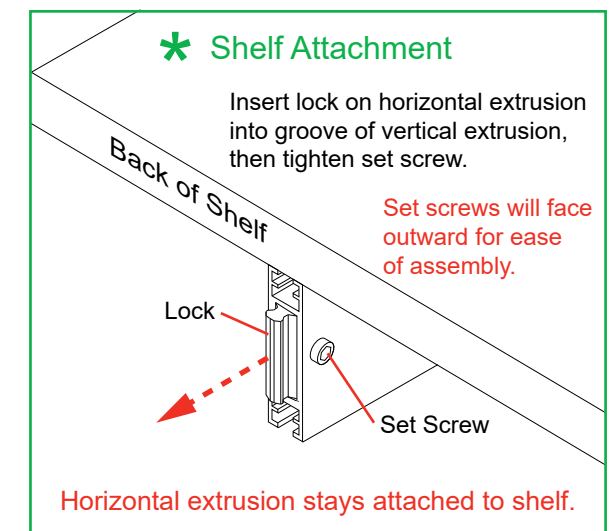
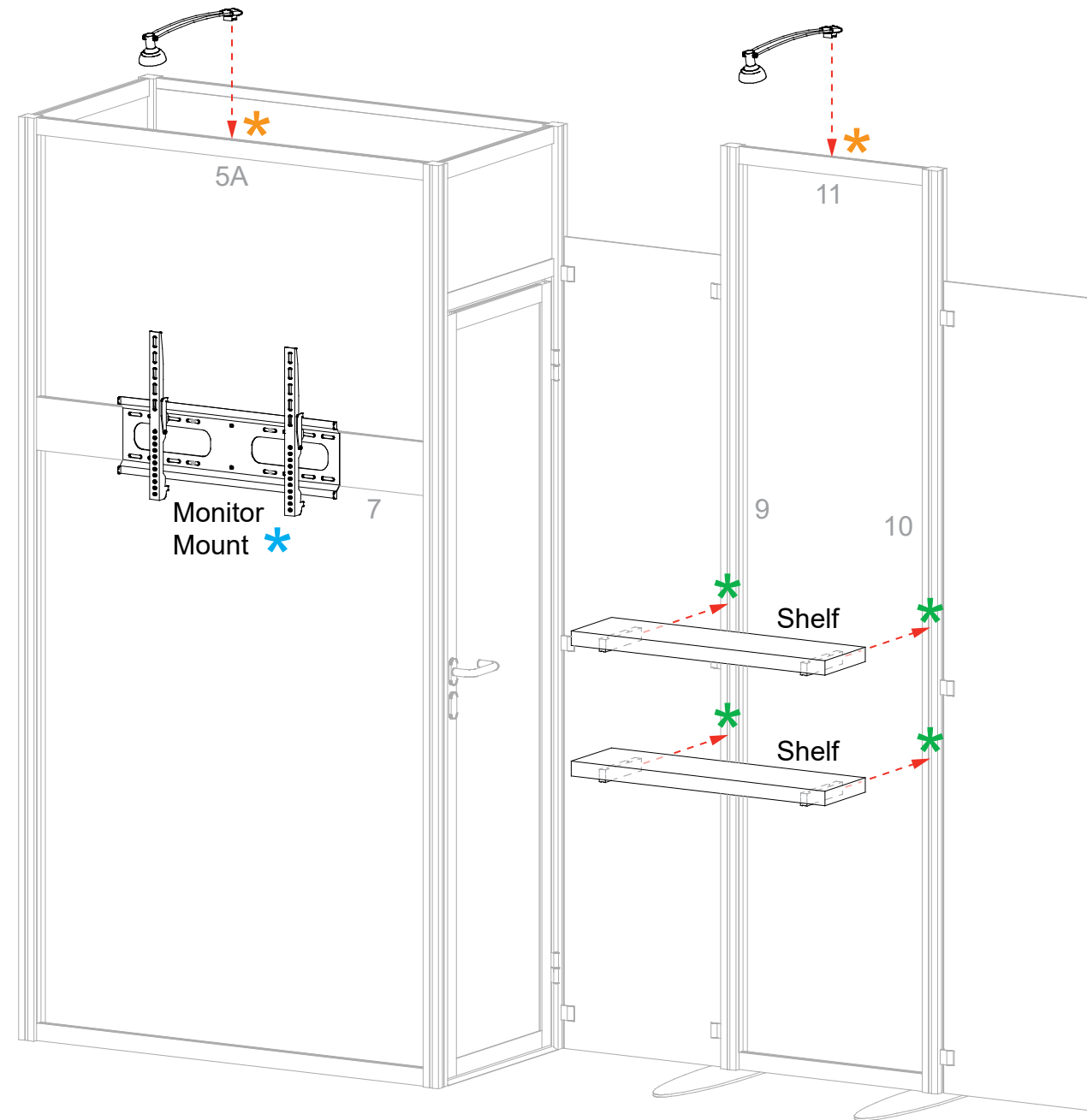
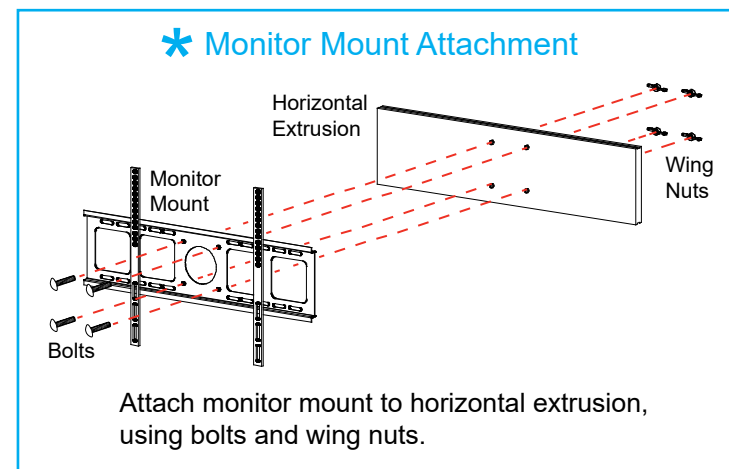
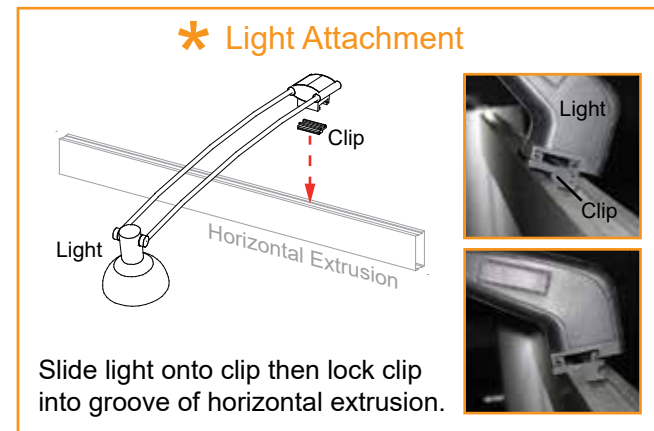
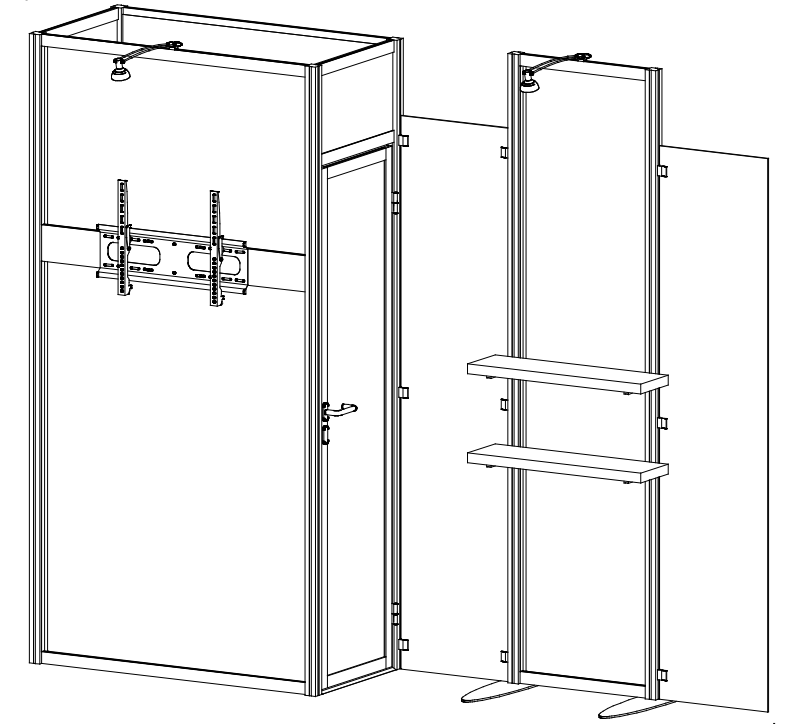

Item	Qty.	Description
1	1	38" h LT Connector
2	1	30" w x 38" h LT Panel w/ Door
3	1	38" h LT Connector
4	1	19" w x 38" h LT Panel
5	1	38" h LT Connector
6	1	30" w x 38" h LT Panel
7	1	38" h LT Connector
8	1	19" w x 38" h LT Panel

- Steps:**
- 1) Assemble panels and connectors in numerical order, making sure Velcro is facing inward.
 - 2) Connect shelf supports to Velcro.
 - 3) Place shelf on top of shelf supports.
 - 4) Lock counter top to panels [4] and [8]. See **Counter Top Lock** detail.
 - 5) Attach graphic to panel [6], using standoffs and caps.

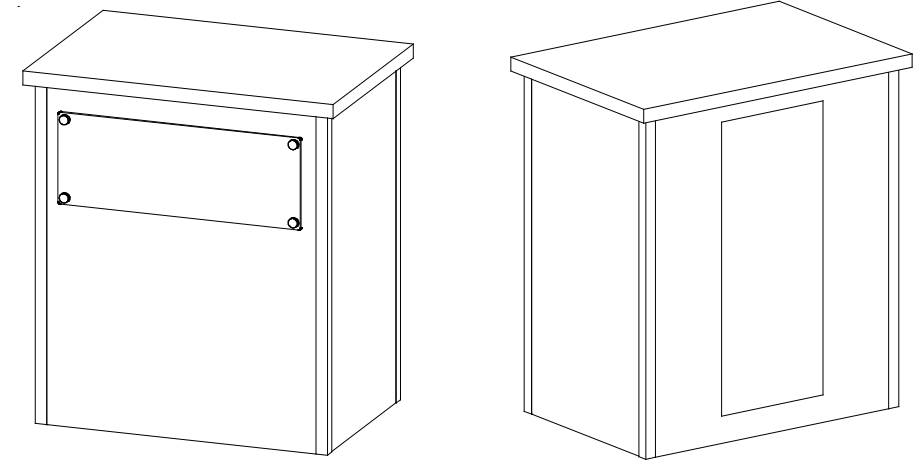

Front View

Back View

Completed Assembly

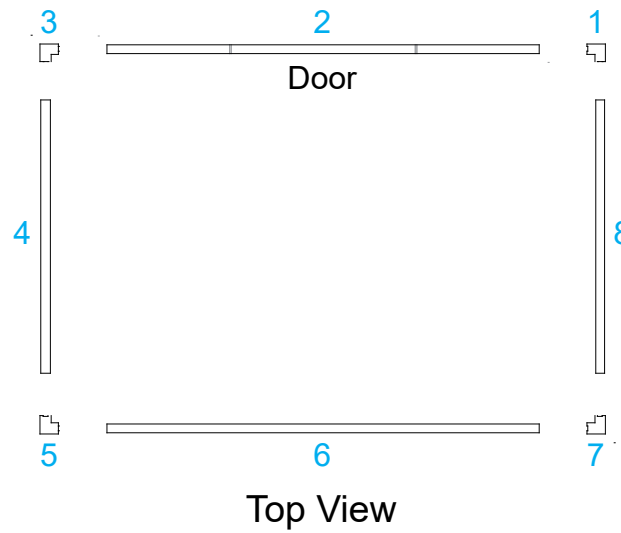

Top View

