

SETUP INSTRUCTIONS

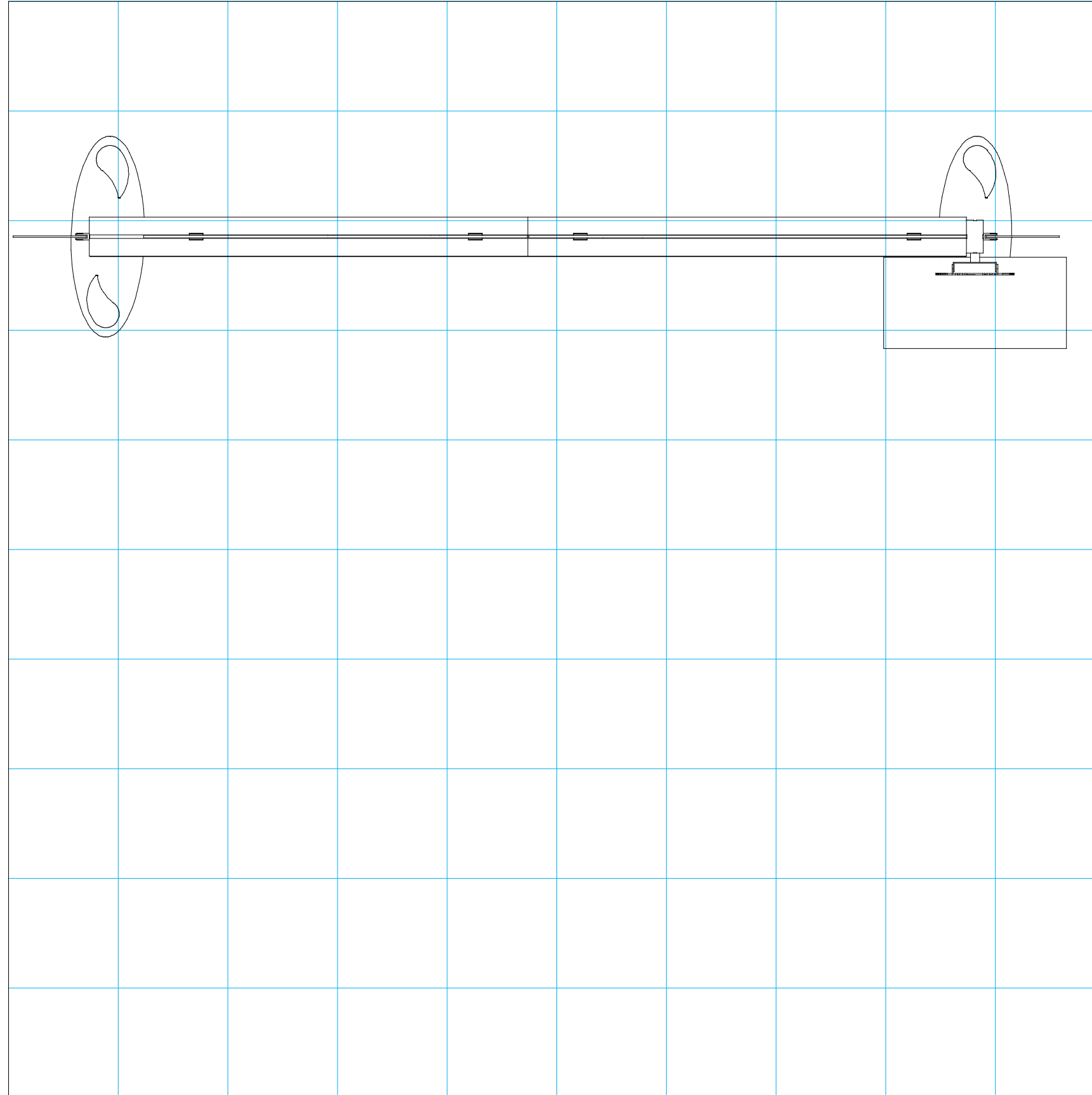

= 1 sq foot

General Setup Instructions

- Read entire setup instruction manual prior to unpacking parts and pieces.
- The setup instructions are created specifically for this configuration.
- Setup instructions are laid out sequentially in steps, including exploded views with detailed explanation for assembly.

Cleaning & Packing

- For Cleaning Metal, Plex, & Laminate Parts: Use a **MILD NON-ABRASIVE** cleanser and soft cloth/paper towel to clean all surfaces.
- Keep exhibit components away from heat and prolonged sun exposure. **Heat and UV exposure will warp and fade components.**
- Retain all provided Packing Materials. All provided packing materials are for ease of repacking & component protection.

Disassembly

- For loss prevention, tighten all set screws and locks during disassembly.

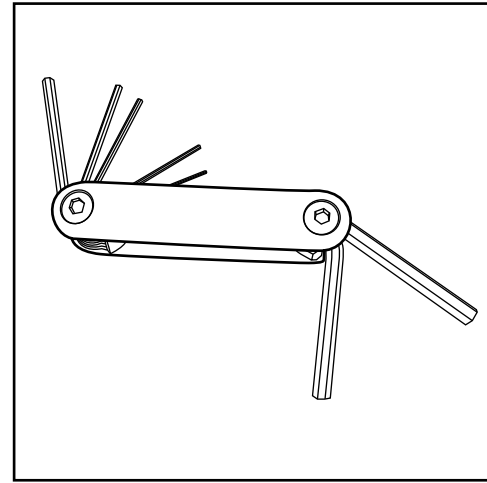

Hex Tool - Essential for Assembly

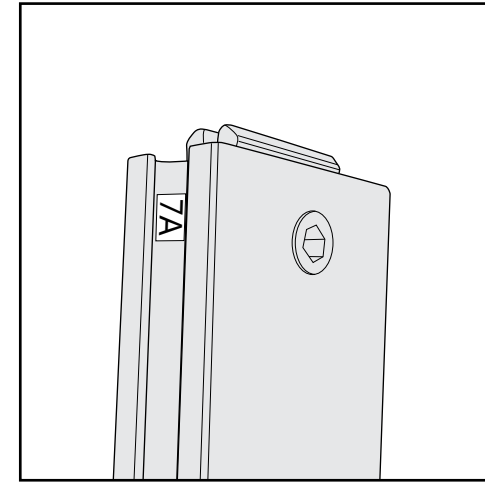

Part Identification - Numbering

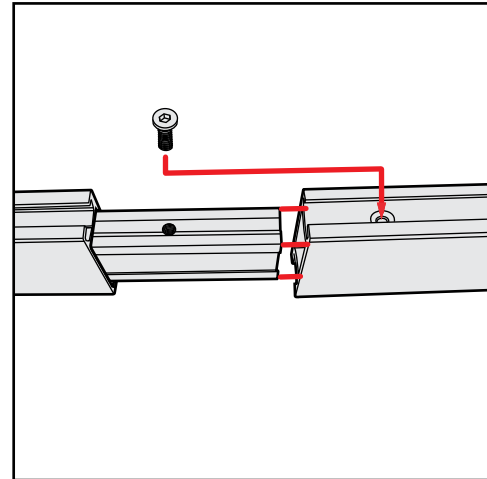

Spline Connection

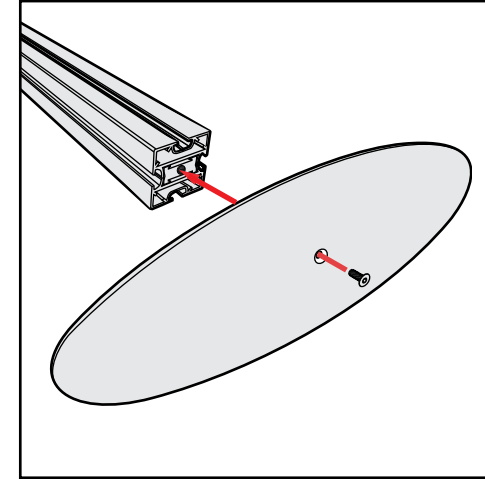

Base Plate & Extrusion Connection

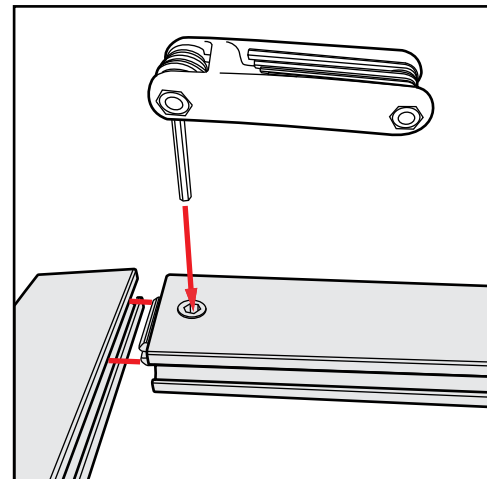

Extrusion & Lock Connection

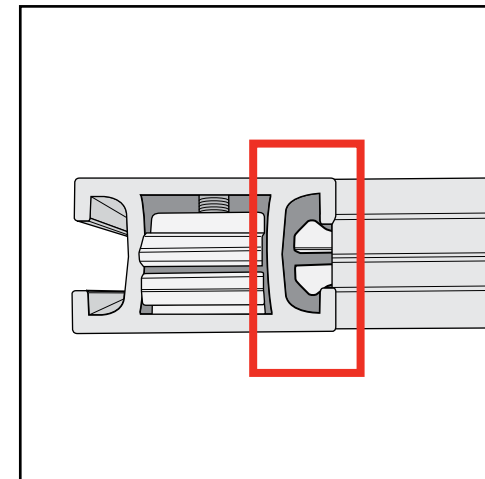

Engaged Lock



WARNING



DO NOT USE POWER TOOLS

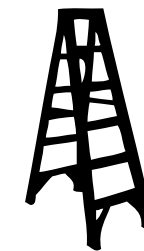

LADDERS OR LIFTS
MAY BE REQUIRED



ALL CONNECTIONS MUST
BE TIGHTLY SECURED

Top View of Each Level

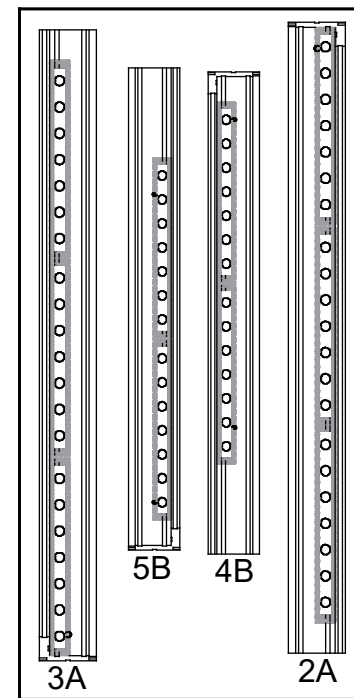

Level 1

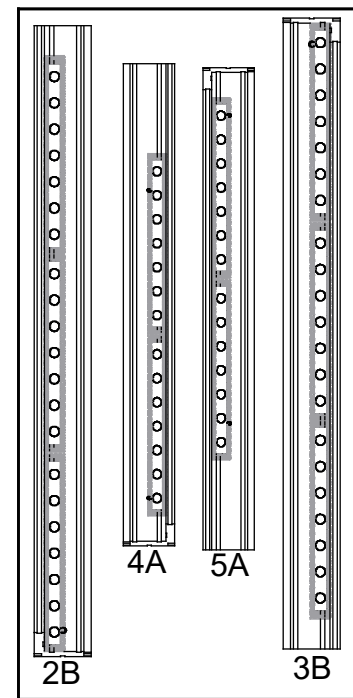

Level 2

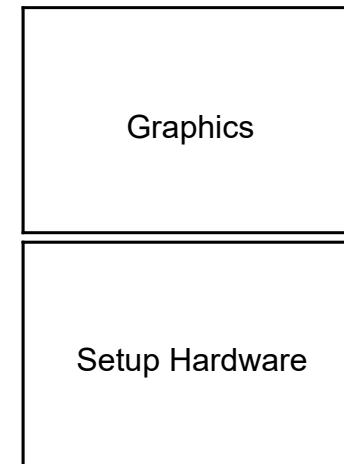

Top View of Each Level

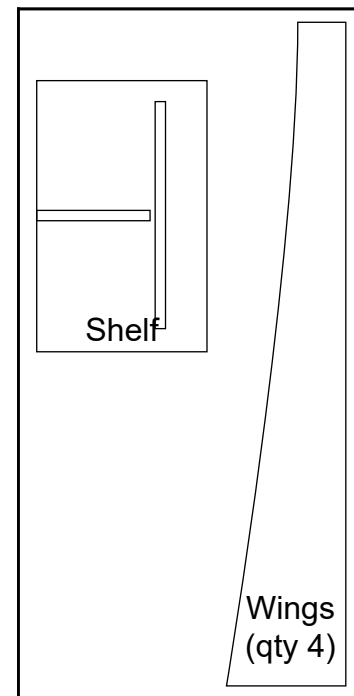

Level 1

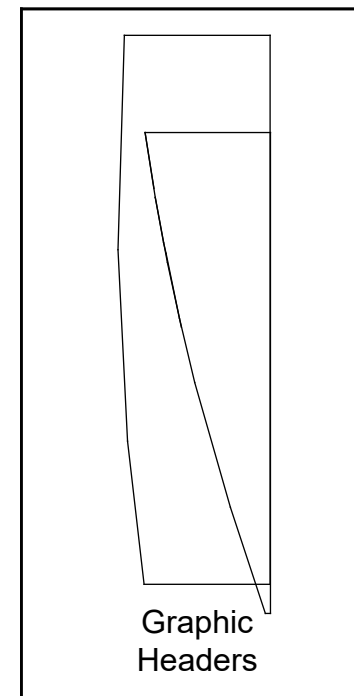

Level 2

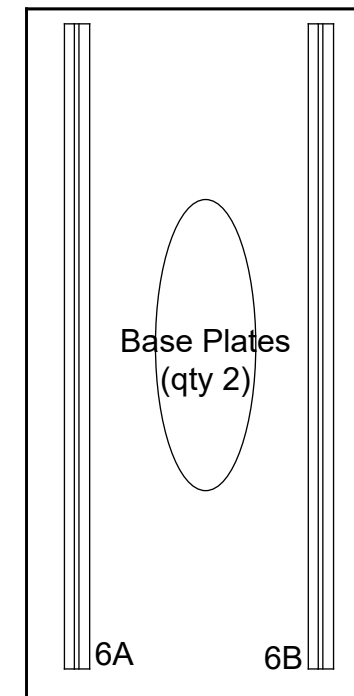

Level 3

Item	Qty.	Description
1A,1B	1,1	Baseplate
2A/2B	1/1	48" CEI110 Horizontal Extrusion
3A/3B	1/1	48" CEI110 Horizontal Extrusion
4A/4B	1/1	40.25" CEI110 Vertical Extrusion
5A/5B	1/1	40.25" CEI110 Vertical Extrusion
6A/6B	1/1	46.8125" S91 Vertical Extrusion

Steps:

- 1) Attach Baseplate [1A] to horizontal [2A] using bolt & wing nut.
- 2) Attach Baseplate [1B] to vertical [6A] using bolt.
- 3) Connect horizontals [2A-3A, 2B-3B] and verticals [4A-5A, 4B-5B, 6A-6B] together. See CEI-110 Frames Assembly in the General Information Pages.
- 4) Connect Horizontal and Vertical assemblies together. See CEI-110 Frames Assembly in the General Information Pages.
- 5) Connect vertical assembly [6A-6B] to vertical assembly [4B-5B], using V4 connectors & bolts as shown.
- 6) Connect lighting **Power Cords** and attach Transformers. See [Light to Light Attachment](#) & [Light to Transformer Attachment](#) details.
- 7) Attach **SEG** to assembled frame. See [SEG Graphic Install](#) in the General Information Pages.

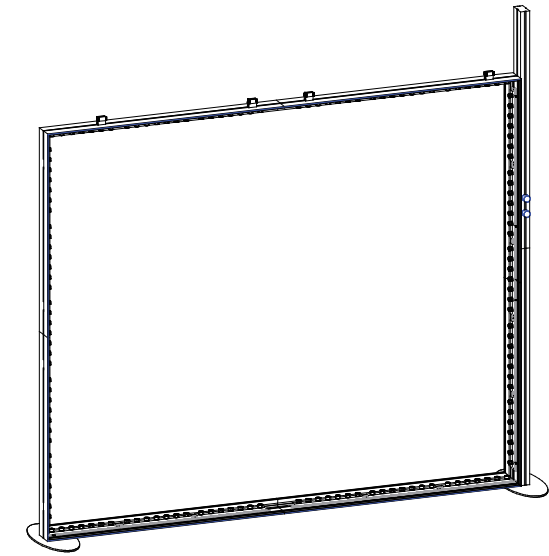
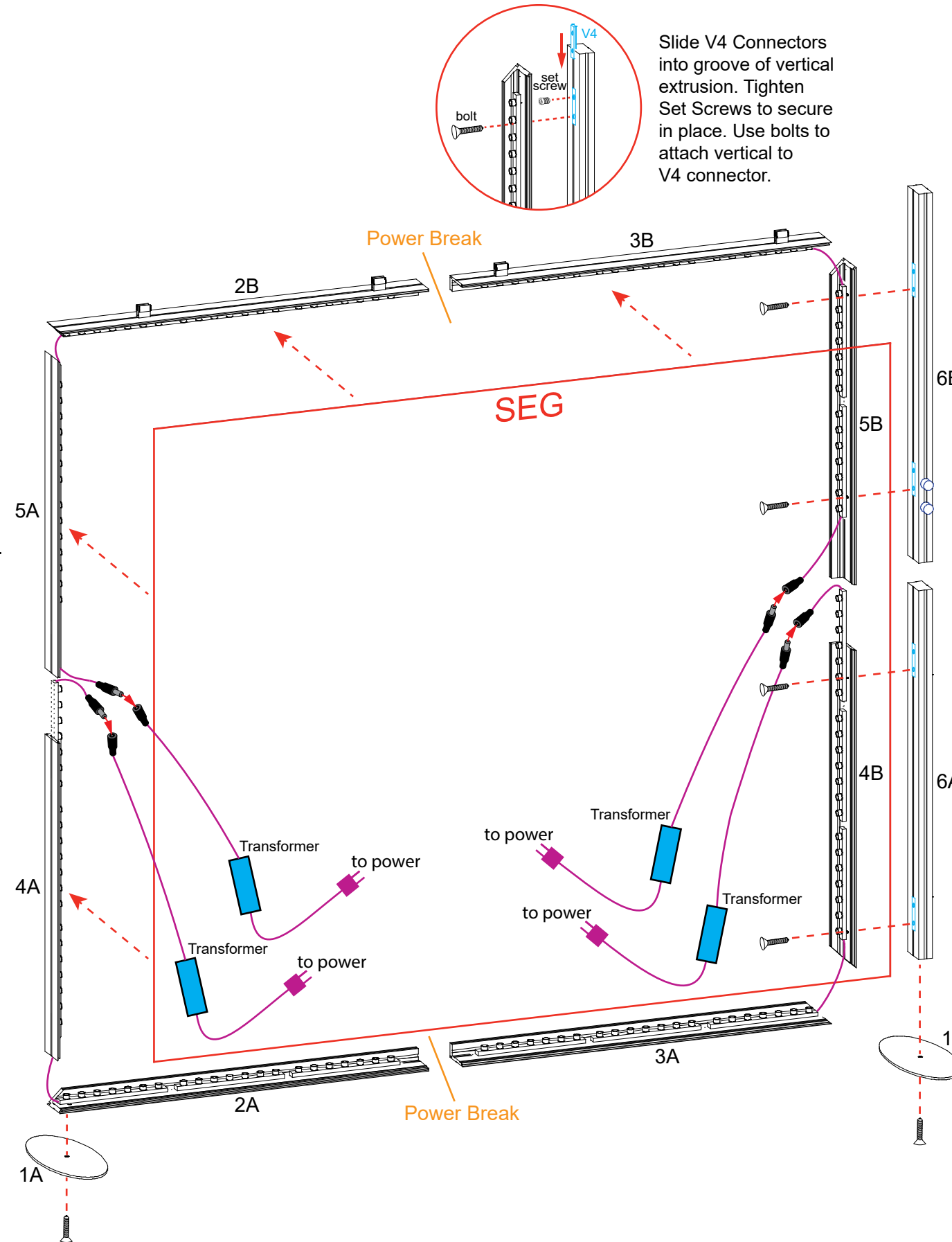

When Assembled

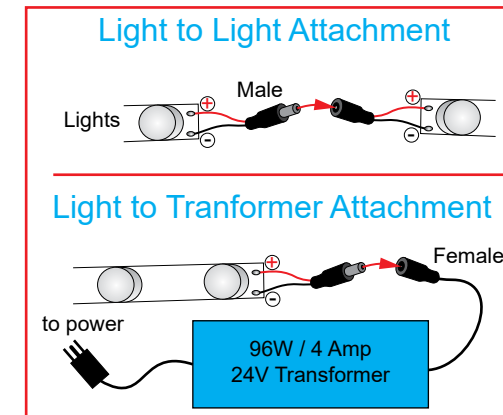

Steps:

- 1) Connect Graphic Headers to assembled backwall with A10 Clamps. See [A10 Clamp](#) detail.
- 2) Connect Shelf to Vertical [6A/6B]. See [Shelf Attachment](#) detail.
- 3) Install Monitor Mount to vertical [6A/6B] as shown. See [Monitor Mount Attachment](#) detail.

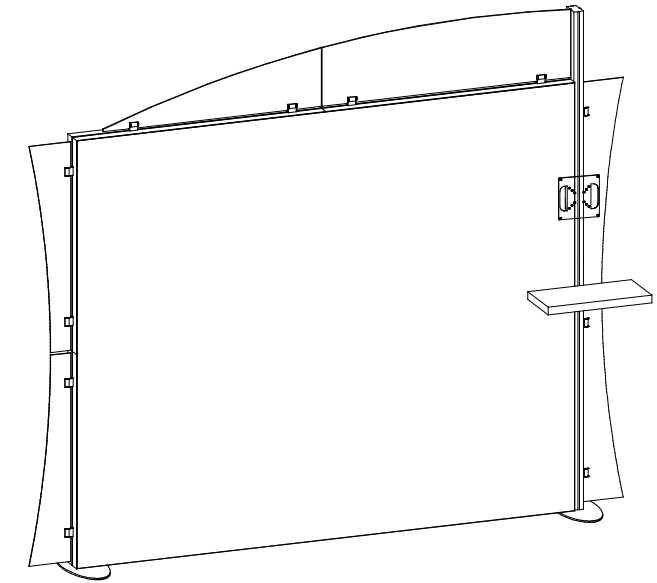

When assembled

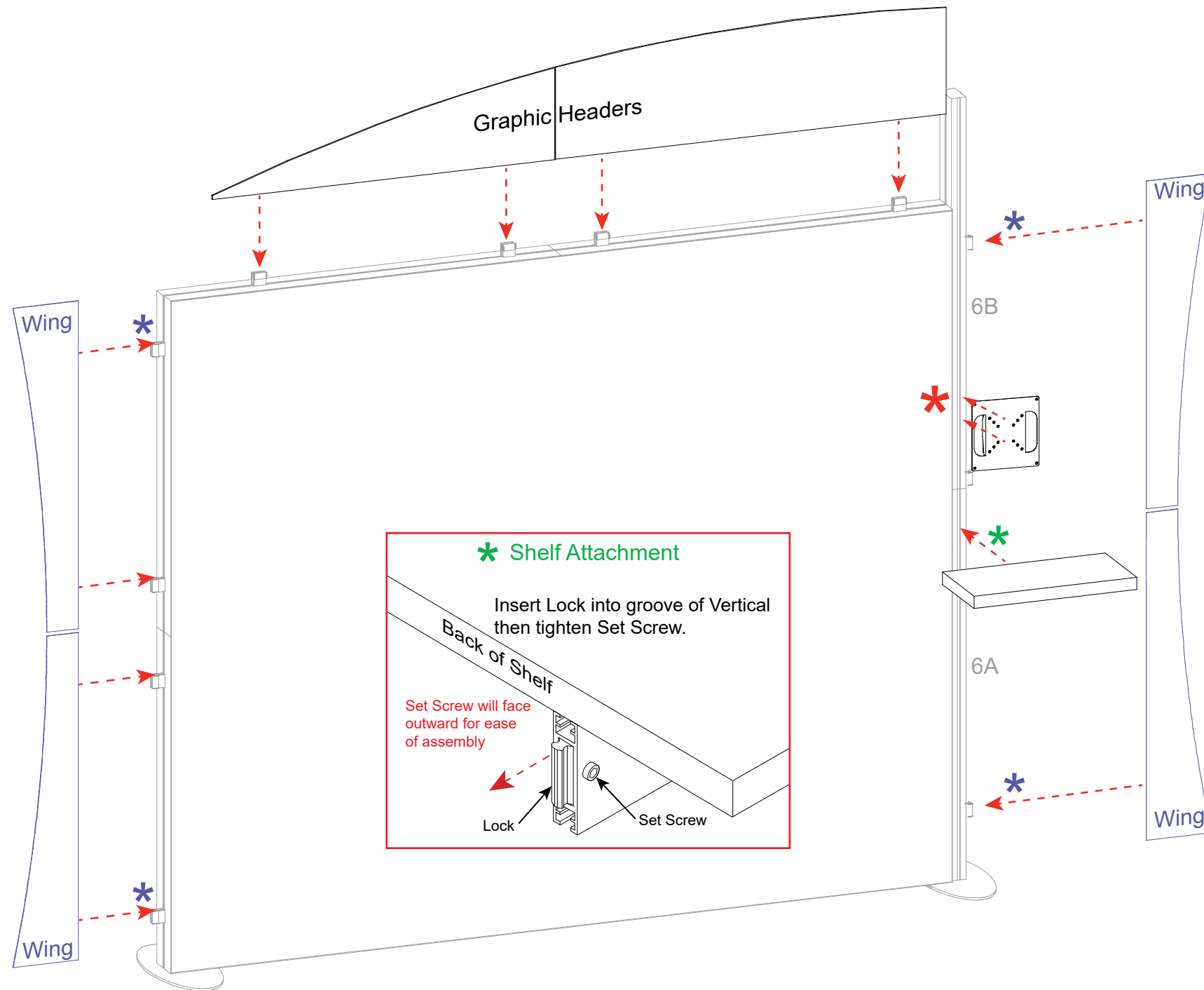

*** Shelf Attachment**

Insert Lock into groove of Vertical then tighten Set Screw.

Back of Shelf

Set Screw will face outward for ease of assembly

Lock Set Screw

*** Monitor Mount Attachment**

V4 Connectors

Stand-Off Barrels

Slide V4 connectors into groove of vertical extrusion, tighten set screws to secure connectors in place.

Attach Standoff Barrels to V4 connectors, then connect Monitor Mount to standoffs using bolts.

*** A10 Clamp**

Wing

- 1) Slide A10 connector into groove of Vertical.
- 2) Tighten Set Screw to secure A10 to Vertical.
- 3) Insert Wing into A10.
- 4) Tighten knob to secure Wing in place.